

SINGLE PILOT OPERATED CHECK VALVES WITH SEPERATE PILOT



VBPSE PS

Flow Upto 35 LPM
Pressure 350 Bar

Description & Operation

These valves are used to block the cylinder in one direction. The flow is free in one direction and blocked in the reverse one until pilot pressure is applied. Separated mounting enables valves to be insensitive to back pressure on the line V2.

Assembly on 2 or more parallel cylinders with a sequence valve to allow balanced and soft descent is highly recommended.

Connect V1 and V2 to the pressure flow and C1 and C2 to the actuator as indicated in the diagram.

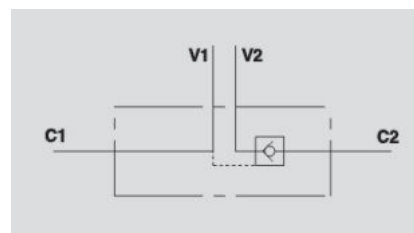

Hydraulic Symbol

Technical Data

Maximum Flow	35 LPM
Maximum Pressure	350 Bar
Body Material	Aluminium, Steel
Internal parts	Hardened and Ground steel
External Component treatment	-
Oil Temperature	50 Deg. C
Fluids	Mineral based or synthetics with lubricating properties
Viscosity	30 cSt
Standard Sealing	NBR-Buna N
Filtration	20/18/15 ISO 4406 (Max. Filtration admitted)
Orientation / Mounting	Inline
Weight	See Ordering details

Specifications

Type	Pilot Ratio	Max.Flow	Max.Pressure	Cr.Pressure
		Bar	Bar	Bar
VBPSE 3/8" PS	1:12	35	350	3

 **Performance Curve**

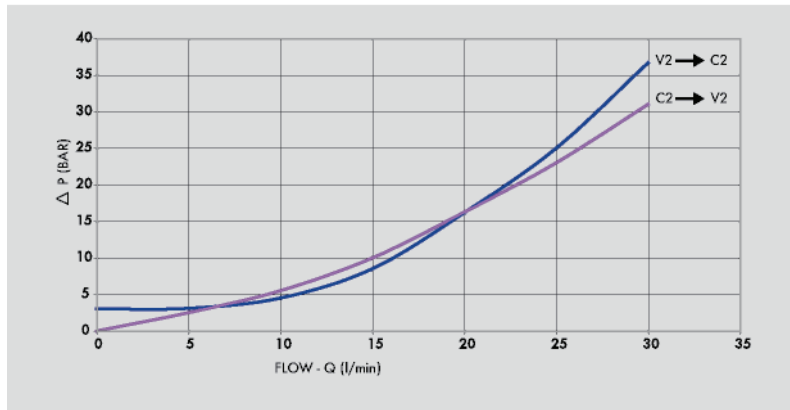

 **Dimensional Drawing**

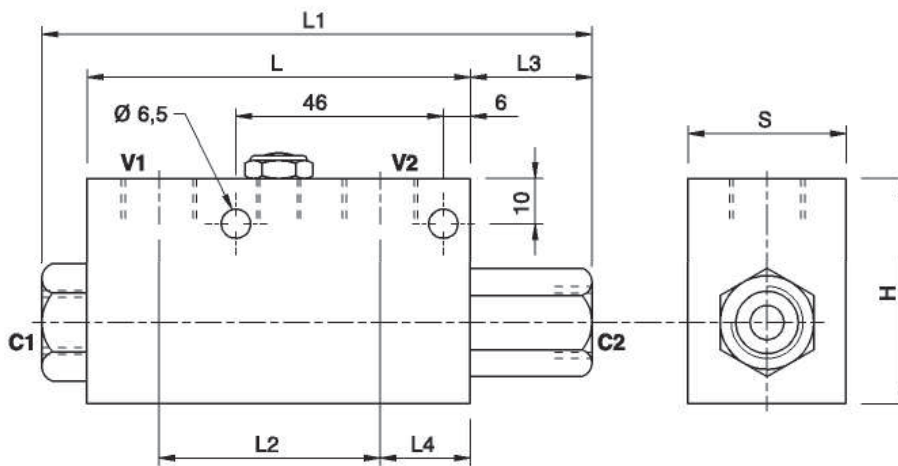

Mounting Diagram

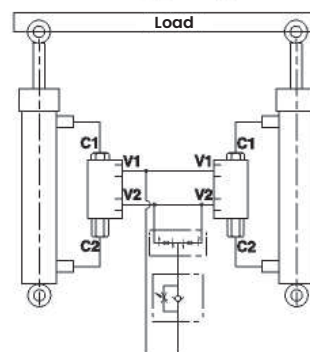

 **Ordering Details**

Code	Type	V1-V2 C1-C2	L	L1	L2	L3	L4	H	S	Weight
		GAS	mm	mm	mm	mm	mm	mm	mm	Kg
R-V0231	VBPSE 3/8" PS	G3/8"	85	122	49	27	20	50	35	0.690