



WE.S0.S08 Valve Series

SAE Cartridge – 350 Bar

NC Single Lock Pilot Operated – Poppet Type

Description & Operation

Solenoid operated, 2-way 2-positions, normally closed, piloted poppet type, screw-in cartridge valve. Typically used as a blocking or load holding device for high pressure circuits. When the coil is de-energized, the WES0.S08 acts as check valve allowing free flow from 1 to 2, while blocking from 2 to 1. When the coil is energized the poppet lifts and opens the 2 to 1 flow path. In this operation mode, flow from 1 to 2 is severely restricted. The rigid design using a 1-piece body contributes to minimize the effect of eccentricities in cavity and provides great reliability. Low pressure drop thanks to optimized flow path

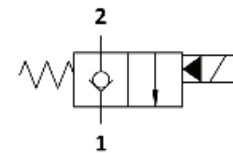
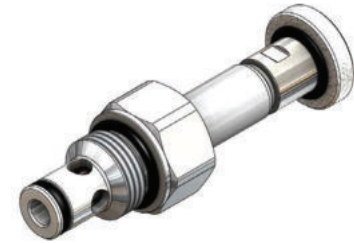

Hydraulic Symbol

Technical Data

Maximum operating pressure	350 Bar
Maximum flow	40 LPM
Maximum internal leakage	0.25 cm ³ /MIN @350 BAR
External component treatment	Zn/Fe - standard (96h) Zn/Ni (720h)
Switch ON Time	30 ms
Switch OFF Time	50 ms
O-ring Temperature Range	-30° C to 110° C (standard sealing NBR - BUNA-N)
Oil Temperature Range	-30 C to 110 C
Fluids	Mineral - based or synthetics with lubricating properties
Viscosities	7.4 to 420 cSt
Minimum pull-in voltage	85% of nominal
Filtration	20/18/15 ISO 4406 (maximum filtration admitted)
Orientation	No restrictions
Installation torque	40 - 45 Nm (Hex. 24)
Oil testing condition	ISO VG 46 cSt
Seal kit code	SLKT.030 & SLKT.027 (COIL)
Coil	18 W
Weight	0.110 kg

 Performance Curve

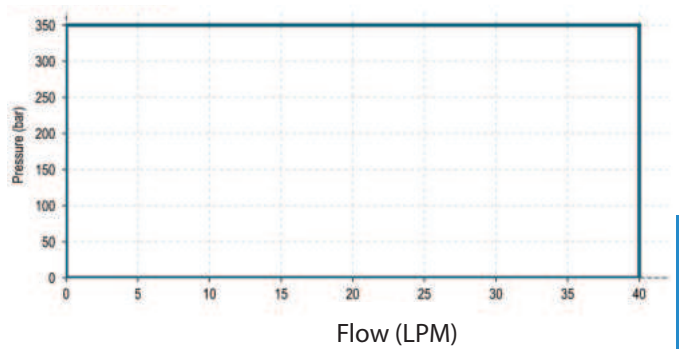
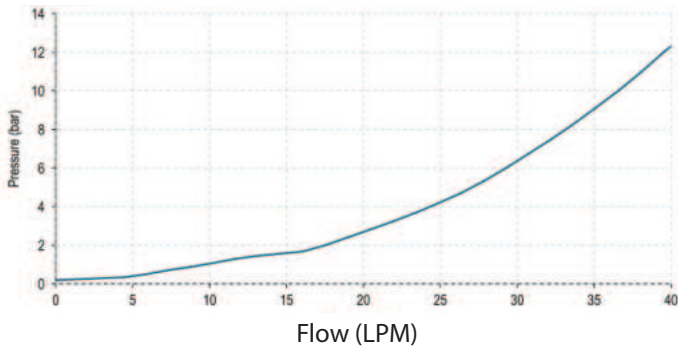

 Dimensional Drawing

Cross Section and Cavity Details

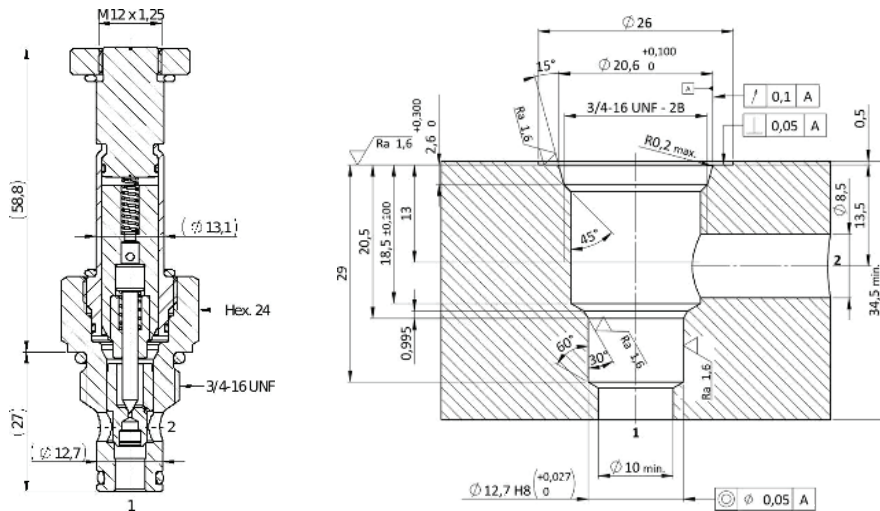

 Ordering Code

W E • S O • S O 8 • 0 * • * 0 0

valve basic code

Cavity

S08 = 3/4- 16 UNF with \varnothing 12.7 nose size
 Other available options:
S09 = 3/4- 16 UNF with \varnothing 15.86 nose sizes
M18 = M18 x 1.5 with \varnothing 12.9 nose size
M20 = M20 x 1.5 with \varnothing 15 nose size

Marking

0 = standard factory marking. customized marking can be done upon request

Manual Override

model Code	Type of Override
0	No Override
1	Screw
2	Push and Twist
6	Push and Hold

Filtration

model Code	Type of Filter
N	No Filter
F	Standard filter (Mesh size 280 μ m)

Note=Customized filters can be done upon request

NOTE: All Solenoid cartridge valves listed in the present catalogue are designed to work with D.C. power supply. To work with A.C. power supply, a RAC coil and connector with rectifier must be used. For any additional information, please contact your Sales contact representative.