



S.H0.S08

SAE08 Cartridge - 420 Bar Direct acting - Ball type

Description & Operation

A screw-in, cartridge style, direct acting, ball type check valve. Main use is as a blocking or load-holding device. The S.H0.S08 allows flow passage from port 1 to 2: the cartridge has a fully guided check which is spring-biased closed until sufficient pressure is applied at port 1 to open to 2. The flow is blocked in the opposite direction (2 to 1).

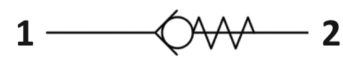

Hydraulic Symbol

Technical Data

Maximum operating pressure	420 Bar
Maximum flow	50 LPM
Cracking pressure	See table below
Maximum Internal Leakage	0.10 cm ³ / min @ 10 Bar 0.10 cm ³ / min @ 420 Bar
External component treatment	Zn/Fe - standard (96h) Zn/Ni (720h) (Upon request)
O-ring Temperature Range	-30° C to 110° C (standard sealing NBR - BUNA-N)
Oil Temperature Range	-30° C to 110° C
Fluids	Mineral - based or synthetics with lubricating properties
Viscosities	7.4 to 420 cSt
Filtration	20/18/15 ISO 4406 (maximum filtration admitted)
Orientation	No restrictions
Installation torque	40-45 Nm
Oil testing condition	ISO VG 46 cSt
Seal kit code	SLKT.030
Weight	0.055 kg

Performance Curve

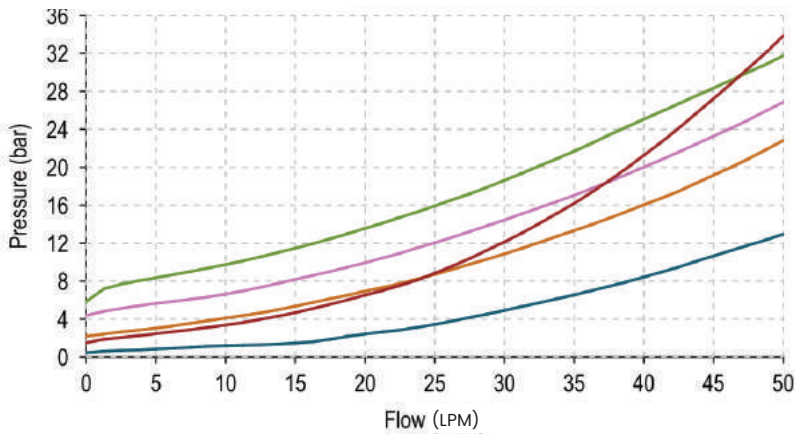

Note:
The performance chart illustrates flow handling capacity for each spring bias option. p/Q curves are recorded at TOil = 40°C and 46 cSt

Dimensional Drawing

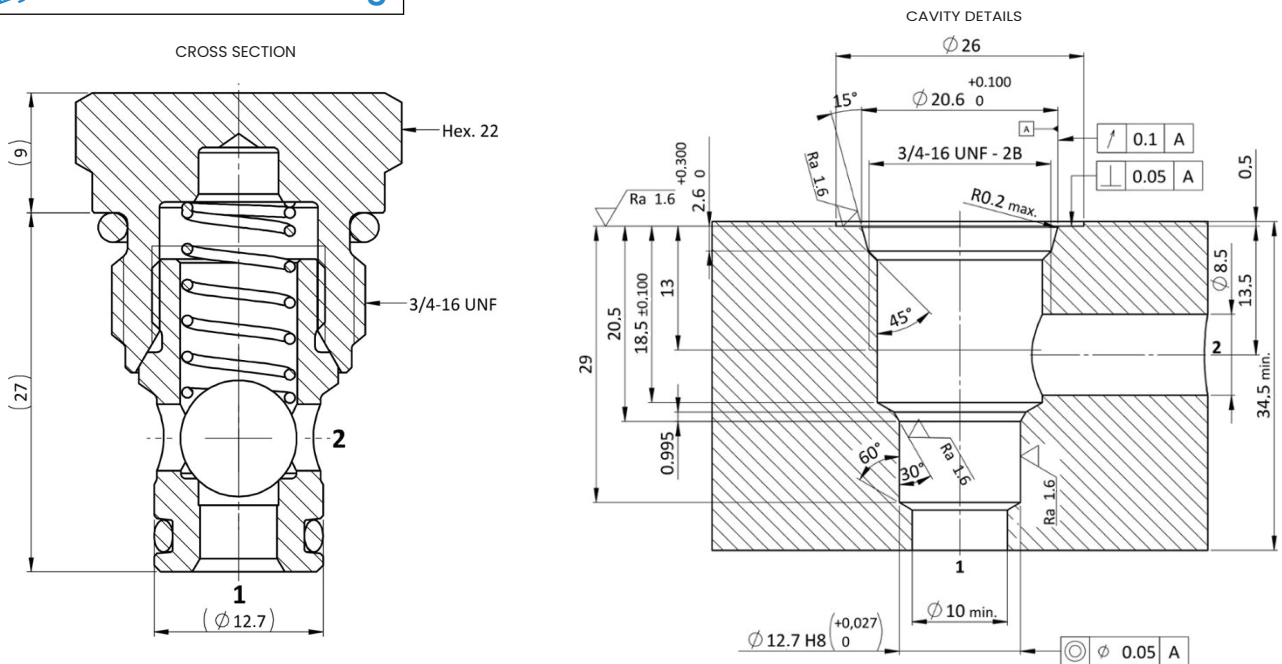

Ordering Code

S • H 0 • S 0 8 • 0 * • 0 0 0

Valve Basic Code

Cavity
S08 = 3/4 - 16 UN
with \varnothing 12.7 nose size

000 = Standard Configuration

Marking
0 = Standard factory marking. Customized marking can be done upon request.

Bias Spring Options

Spring model code	Cracking pressure (Bar)
Y	0.5
N	1.5
M	2.0
P	4.5
U	6