



S.D0.G34 Valve Series

GAS Insert - 350 Bar

Direct acting - Poppet type

Description & Operation

A screw-in, direct acting, poppet type in-line check valve. Main use is as a blocking or load-holding device. The S.D0.G34 allows flow passage from port 1 to 2: the cartridge has a fully guided check which is spring-biased closed until sufficient pressure is applied at port 1 to open to 2. The flow is blocked in the opposite direction (2 to 1).



Hydraulic Symbol

Technical Data

Maximum operating pressure	350 Bar
Maximum flow	120 LPM
Maximum internal leakage	0.1 cm ³ / min @ 10 Bar 0.1 cm ³ / min @ 350 Bar
External component treatment	Zn/Fe - standard (96h) Zn/Ni (720h)
O-ring Temperature Range	-30° C to 110° C (standard sealing NBR - BUNA-N)
Oil Temperature Range	-30° C to 110° C
Fluids	Mineral - based or synthetics with lubricating properties
Viscosities	7.4 to 420 cSt
Filtration	20/18/15 ISO 4406 (maximum filtration admitted)
Orientation	No restrictions
Installation Toll	IK.005
Installation torque	50 Nm
Oil testing condition	ISO VG 46 cSt
Seal kit code	SLKT.015
Weight	0.040 kg

 Performance Curve

Spring N

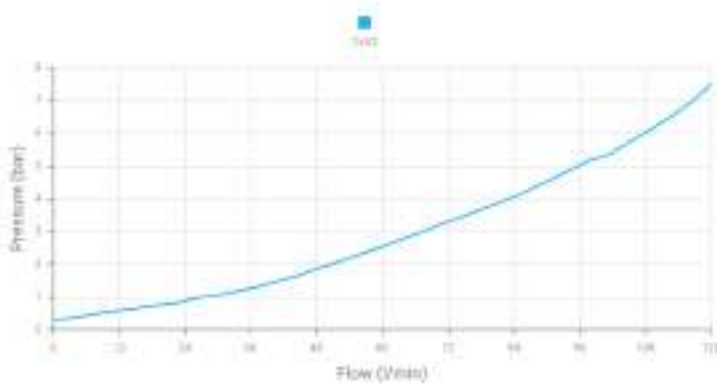

Note:

The performance chart illustrates flow handling capacity. p/Q curves are recorded at TOil = 40°C and 46 cSt.

 Dimensional Drawing

Cross Section and Cavity Details

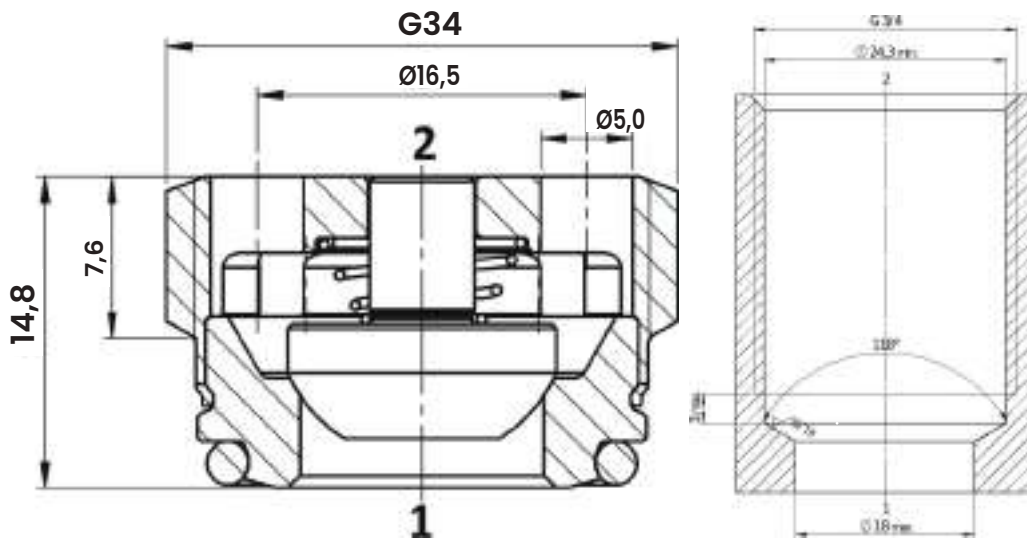

 Ordering Code

S	•	D	0	•	G	3	4	•	0	*	•	0	0	0
valve basic code											000= standard configuration			

Cavity
G34 = METRIC G12 x 1

Marking
0 =standard factory marking. customized marking can be done upon request

Bias spring Options

Spring Model Code	Cracking pressure (Bar)
N	0.5