



S.D0.G18 Valve Series

GAS Insert - 350 bar

Direct acting - Poppet type



Description & Operation

A screw-in, direct acting, poppet type in-line check valve. Main use is as a blocking or load-holding device. The S.D0.G18 allows flow passage from port 1 to 2: the cartridge has a fully guided check which is spring-biased closed until sufficient pressure is applied at port 1 to open to 2. The flow is blocked in the opposite direction (2 to 1).



Hydraulic Symbol



Technical Data

Maximum operating pressure	350 Bar
Maximum flow	10 LPM
Maximum internal leakage	0.1 cm ³ / min @ 10 Bar 0.1 cm ³ / min @ 350 Bar
External component treatment	Zn/Fe - standard (96h) Zn/Ni (720h)
O-ring Temperature Range	-30° C to 110° C (standard sealing NBR - BUNA-N)
Oil Temperature Range	-30° C to 110° C
Fluids	Mineral - based or synthetics with lubricating properties
Viscosities	7.4 to 420 cSt
Filtration	20/18/15 ISO 4406 (maximum filtration admitted)
Orientation	No restrictions
Installation Toll	IK.001
Installation torque	6 Nm
Oil testing condition	ISO VG 46 cSt
Seal kit code	SLKT.103
Weight	0.002 kg

 **Performance Curve**

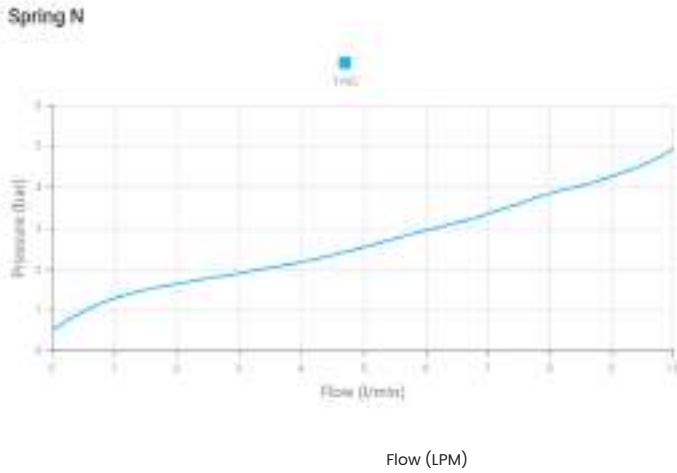

Note:
The performance chart illustrates flow handling capacity. p/Q curves are recorded at TOil = 40°C and 46 cSt.

 **Dimensional Drawing**

Cross Section and Cavity Details

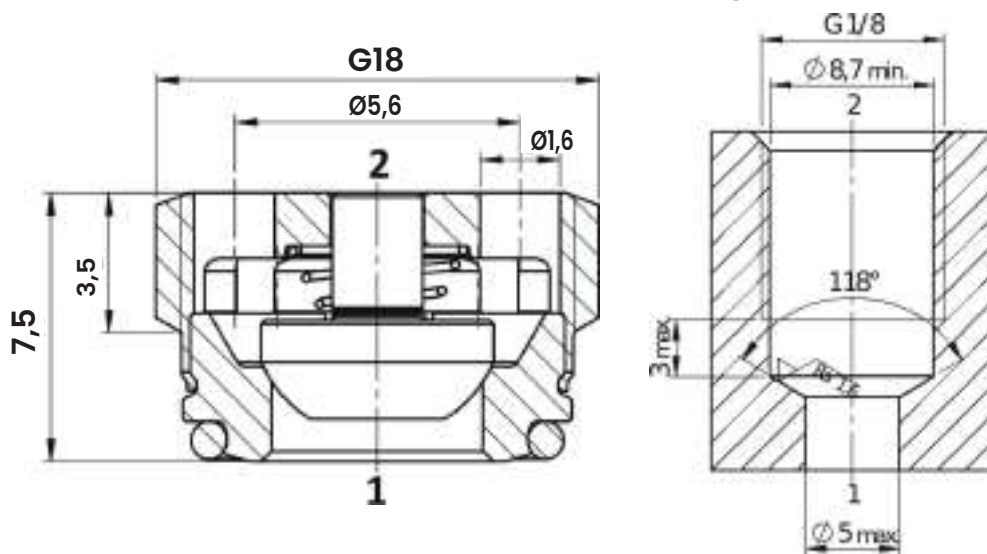

 **Ordering Code**

S	•	D	0	•	G	1	8	•	0	*	•	0	0	0	
valve basic code													000= standard configuration		

Cavity
G18 = METRIC G18 x 1

Marking
0 = standard factory marking. customized marking can be done upon request

Bias Spring Options

Spring Model Code	Cracking Pressure (Bar)
N	0.5