



Check Valves

S.C0.S20 Valve Series

SAE20 Cartridge - 350 Bar
Direct acting - Poppet type

Description & Operation

A screw-in, cartridge style, direct acting, poppet type check valve. Main use is as a blocking or load-holding device. The S.C0.S20 allows flow passage from port 1 to 2: the cartridge has a fully guided check which is spring-biased closed until sufficient pressure is applied at port 1 to open to 2. The flow is blocked in the opposite direction (2 to 1)

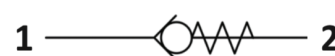

Hydraulic Symbol

Technical Data

Maximum operating pressure	350 Bar
Maximum flow	400 LPM
Cracking pressure	See table below
Maximum Internal Leakage	0.10 cm ³ / min @ 10 Bar 0.10 cm ³ / min @ 350 Bar
External component treatment	Zn/Fe - standard (96h) Zn/Ni (720h) (Upon request)
O-ring Temperature Range	-30° C to 110° C (standard sealing NBR - BUNA-N)
Oil Temperature Range	-30° C to 110° C
Fluids	Mineral - based or synthetics with lubricating properties
Viscosities	7.4 to 420 cSt
Filtration	20/18/15 ISO 4406 (maximum filtration admitted)
Orientation	No restrictions
Installation torque	200 - 215 Nm
Oil testing condition	ISO VG 46 cSt
Seal kit code	SLKT.078
Weight	0.558 kg

Performance Curve

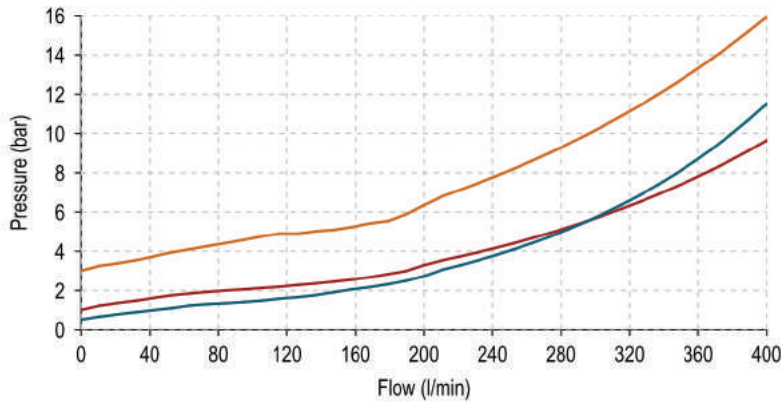

NOTE
 The performance chart illustrates flow handling capacity for significant spring bias options. P/Q curves are recorded at TOI = 40°C and 46 cSt. P/Q curves are recorded up to 200l/LPM. These are theoretical 200 l/LPM Onward.

LEGEND
 — Spring Y
 — Spring N
 — Spring B

Dimensional Drawing

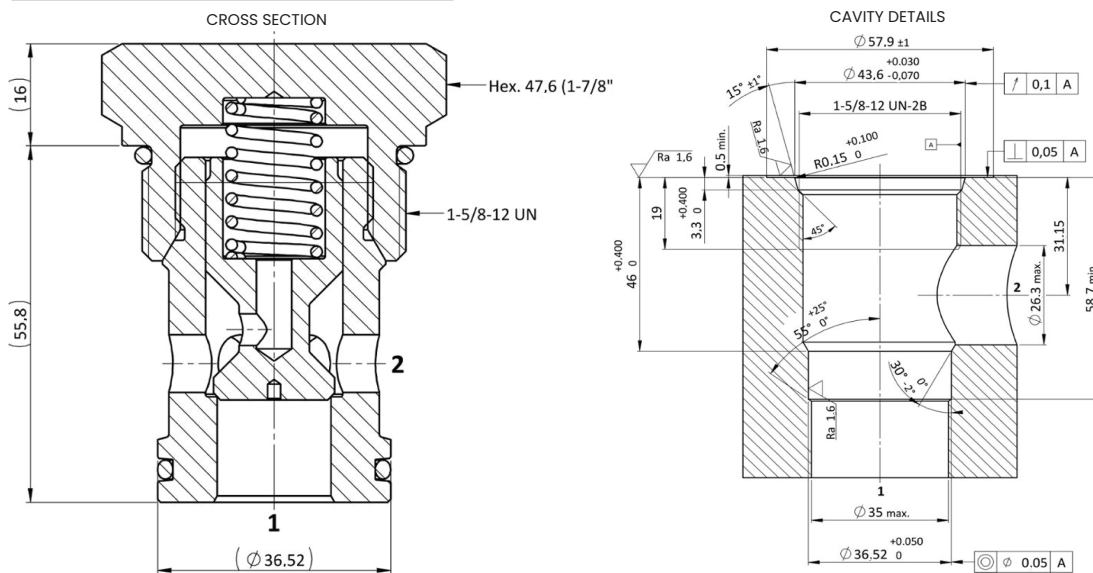

Ordering Code

S • C 0 • S 2 0 • 0 * • 0 0 0

Valve Basic Code

Cavity
 S20 = 1-5/8-12 UNF
 with \varnothing 36.52 nose size

000= Standard Configuration

Marking
 0 = Standard factory marking. Customized marking can be done upon request.

Bias Spring Options

Spring Model Code	Cracking Pressure (Bar)
Y	0.5
N	1.0
B	3.0