



S.CO.S10 Valves Series

SAE10 Cartridge - 420 Bar
Direct acting - Poppet type



Description

A screw-in, cartridge style, direct acting, poppet type check valve. Main use is as a blocking or load-holding device. The S.CO.S10 allows flow passage from port 1 to 2: the cartridge has a fully guided check which is spring-biased closed until sufficient pressure is applied at port 1 to open to 2. The flow is blocked in the opposite direction (2 to 1).

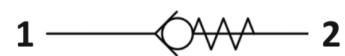

Hydraulic Symbol

Technical Characteristics

Maximum operating pressure	420 Bar
Maximum flow	80 LPM
Internal Parts	Hardened and Brown steel
Cracking pressure	See table below
Maximum Internal Leakage	0.10 cm ³ / min @ 10 Bar 0.10 cm ³ / min @ 420 Bar
External component treatment	Zn/Fe - standard (96h) Zn/Ni (720h)
O-ring Temperature Range	-30° C to 110° C (standard sealing NBR - BUNA-N)
Oil Temperature Range	-30° C to 110° C
Fluids	Mineral - based or synthetics with lubricating properties
Viscosities	7.4 to 420 cSt
Filtration	20/18/15 ISO 4406 (maximum filtration admitted)
Orientation	No restrictions
Installation torque	55-65 Nm
Oil testing condition	ISO VG 46 cSt
Seal kit code	SLKT.032
Weight	0.090 kg

Performance Graph

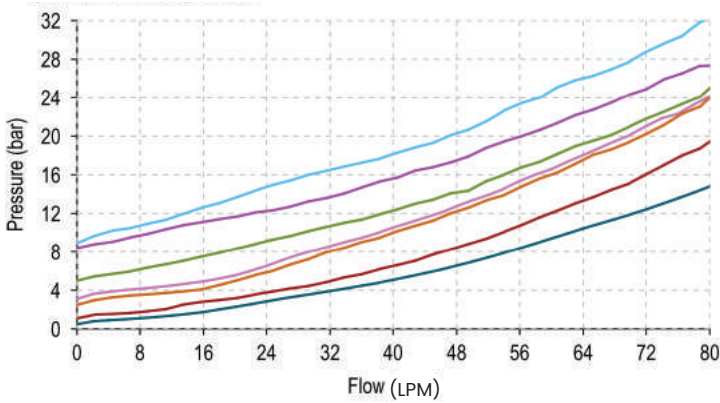

NOTE
The performance chart illustrates flow handling capacity for significant spring bias options. P/Q curves are recorded at T Oil = 40°C and 46 cSt.

LEGEND
 Spring Y Spring P
 Spring N Spring G
 Spring S Spring V
 Spring B

Dimensional Drawing

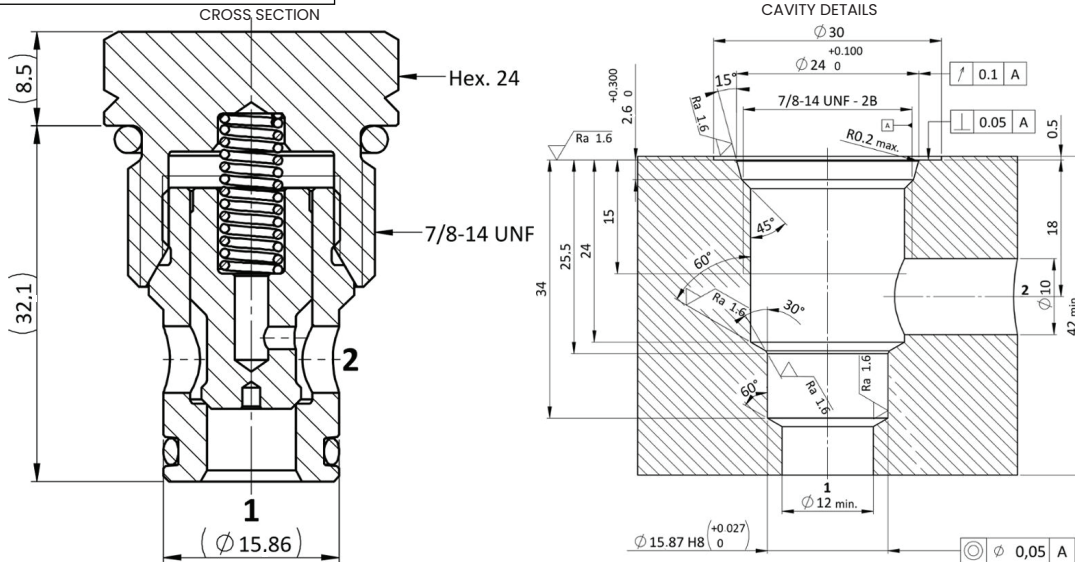

Ordering Code

S • C 0 • S 1 0 • 0 * • 0 0 0

Valve Basic Code

Cavity
S10 = 7/8 -14 UNF with \varnothing 15.86 nose size

000= Standard Configuration

Marking
0 = Standard factory marking. Customized marking can be done upon request.

Bias Spring Options

Spring Model Code	Cracking Pressure (Bar)	Spring Model Code	Cracking Pressure (Bar)
Y	0.5	P	5.0
N	1.0	G	8.0
S	2.5	V	9.0
B	3.0		