



## S.B0.G12 Valve Series

**METRIC Cartridge - 350 Bar**

**Direct acting - Poppet type**



### Description & Operation

A screw-in, direct acting, ball type in-line check valve. Main use is as a blocking or load-holding device. The S.B0.G12 allows flow passage from port 1 to 2: the cartridge has a fully guided check which is spring-biased closed until sufficient pressure is applied at port 1 to open to 2. The flow is blocked in the opposite direction (2 to 1).



Hydraulic Symbol



### Technical Data

Maximum operating pressure	350 Bar
Maximum flow	50 LPM
Maximum Internal leakage	0.1 cm <sup>3</sup> / min @ 10 Bar 0.1 cm <sup>3</sup> / min @ 350 Bar
External component treatment	Zn/Fe - standard (96h) Zn/Ni (720h)
O-ring Temperature Range	-30° C to 110° C (standard sealing NBR - BUNA-N)
Oil Temperature Range	-30° C to 110° C
Fluids	Mineral - based or synthetics with lubricating properties
Viscosities	7.4 to 420 cSt
Filtration	20/18/15 ISO 4406 (maximum filtration admitted)
Orientation	No restrictions
Installation Tool	IK.009
Installation torque	10 Nm Hex 5
Oil testing condition	ISO VG 46 cSt
Seal kit code	SLKT.018
Weight	0.041 kg

**Performance Curve**

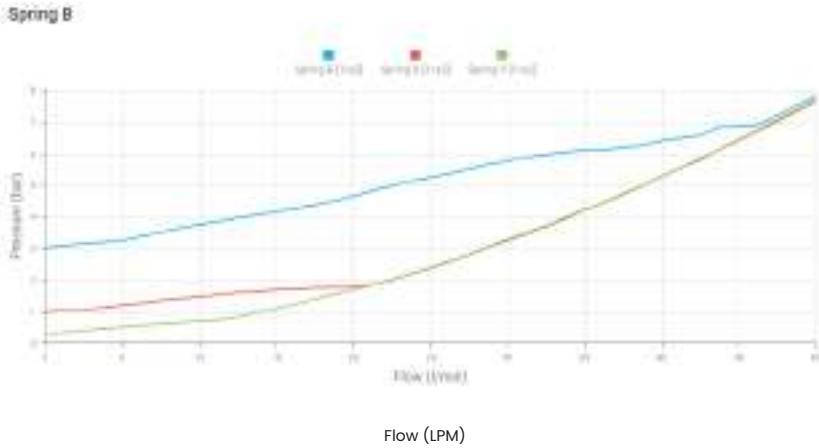

**Note:**  
The performance chart illustrates flow handling capacity for standard bias springs. p/Q curves are recorded at TOil = 40°C and 46 cSt

**Dimensional Drawing**

**Cross Section and Cavity Details**

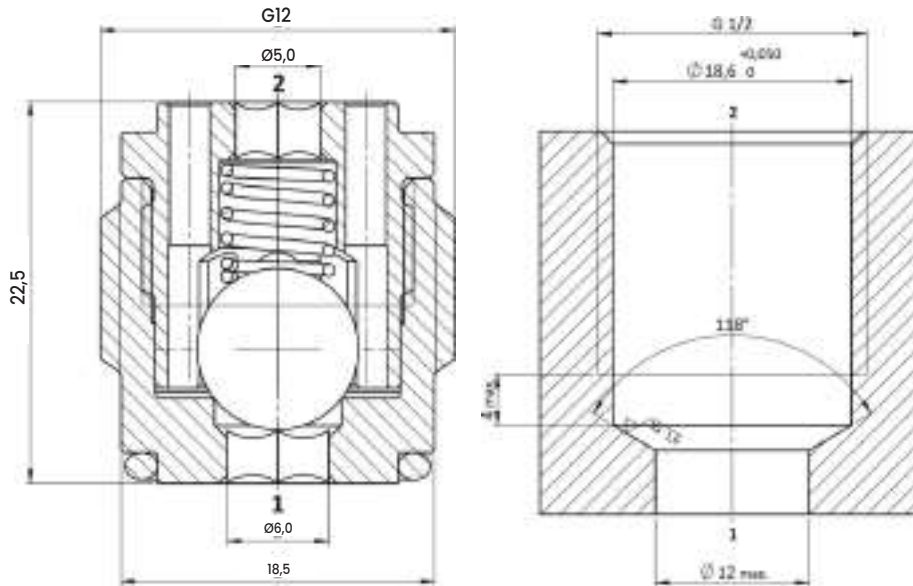

**Ordering Code**

**S** • **B** **0** • **G** **1** **2** • **0** \* • **0** **0** **0**

valve basic code 000= standard configuration

**Cavity**  
G12 = METRIC G38 x 1

**Marking**  
0 = standard factory marking. customized marking can be done upon request

**Bias Spring Options**

Spring Model Code	Cracking pressure (Bar)
X	3.0
Y	118
Z	12.9
W	07

**CHECK VALVES**