



Pilot Check Valves

PC.R0.S10 Valve Series

Hybrid SAE10 Cartridge – 350 Bar

Direct acting check valve

Pilot piston to open



Description & Operation

Normally closed, dual pilot check valve. Cartridge is closed until sufficient pressure is applied on port 1 to reach the bias spring setting, lift the poppet and allow free flow to 2. The valve is normally closed from 2 to 1. When sufficient pressure is applied on port 3, the pilot piston lifts the poppet from its seat and allows flow from 2 to 1. Very limited leakage in the check condition

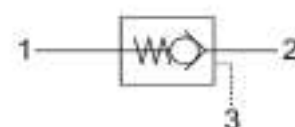

Hydraulic Symbol



Technical Data

Maximum operating pressure	350 Bar
Maximum flow	60 LPM
Maximum internal leakage	0.10 cm ³ / min @ 10 Bar 0.10 cm ³ / min @ 420 Bar
Pilot Ratio	3.9:1
External component treatment	Zn/Fe - standard (96h) Zn/Ni (720h)
O-ring Temperature Range	-30° C to 110° C (standard sealing NBR - BUNA-N)
Oil Temperature Range	-30° C to 110° C
Fluids	Mineral - based or synthetics with lubricating properties
Viscosities	7.4 to 420 cSt
Filtration	20/18/15 ISO 4406 (maximum filtration admitted)
Orientation	No restrictions
Installation torque	40-45- 24 Nm
Oil testing condition	ISO VG 46 cSt
Seal kit code	SLKT.048
Weight	0.110 kg

 **Performance Curve**

Spring Y:

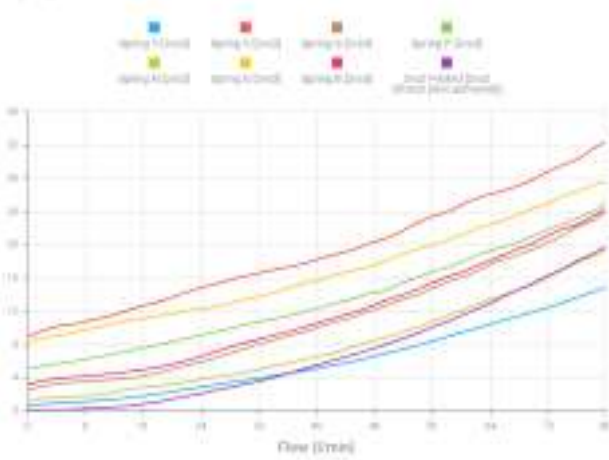

Note:
The performance chart illustrates flow handling capacity for significant spring options. p/Q curves are recorded at TOil = 40°C and 46 cSt.

 **Dimensional Drawing**

Cross Section and Cavity Details

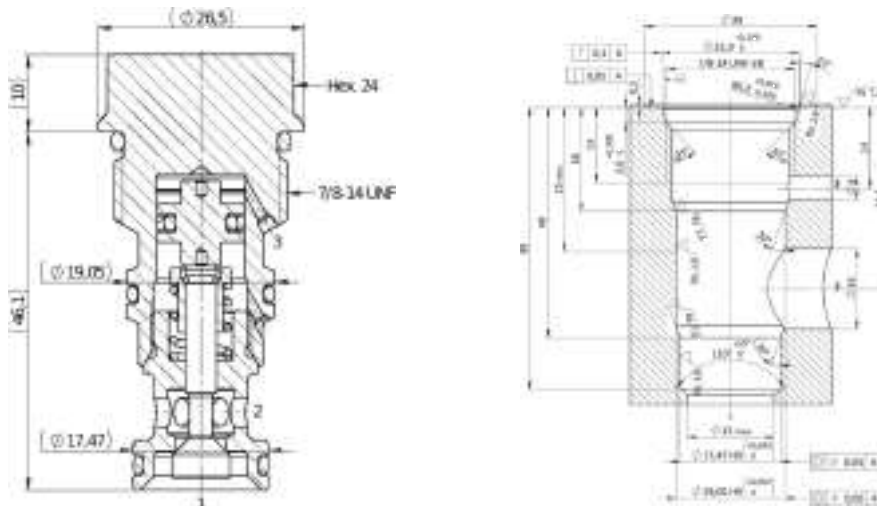

 **Ordering Code**

P C • R 0 • S 1 0 • 0 * • 0 0 0

valve basic code

Cavity
S10 = 7/8 - 14 UNF
with ø15.86 nose size

Marking
0 = standard factory marking. customized marking can be done upon request

000= standard configuration

Options
B=Without O-Ring on the pilot piston

Bias spring

Spring model Code	Cracking Pressure (Bar)	Spring model Code	Cracking Pressure (Bar)
Y	0.5	P	5.0
N	1.0	G	8.0
S	2.5	V	9.0
B	3.0		