

# VALVE FOR ROW MARKER ON SEEDING MACHINE



## VDSF

**Pressure 350 Bar**

### Description & Operation

This type of valves is used on seeding machines to control the row marker. It allows the automatic ascent /descent inversion of single and double effect actuators, loading and unloading the port P/T. Connect P/T to the pressure flow and A and B to the actuator.

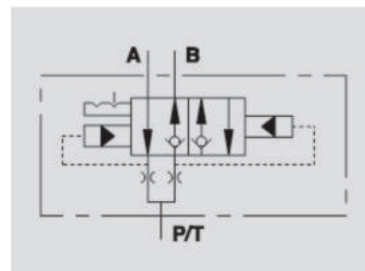

Hydraulic Symbol

### Technical Data

Maximum flow	/
Maximum Operating Pressure	350 Bar
Body Material	Steel
Internal Parts	Hardened and Ground steel
External Component treatment	Zn/Fe - standard (96h) / Zn/Ni (720h)
Oil Temperature	50 Deg. C
Fluids	Mineral based or synthetics with lubricating properties
Viscosity	30 cSt
Standard Sealing	NBR-Buna N
Filtration	20/18/15 ISO 4406 ( Max. Filtration admitted)
Orientation / Mounting	Inline
Weight	See Ordering details

### Specifications

Type	Max Pressure
	Bar
VDSF 3/4" - 16 UNF	350

 **Dimensional Drawing**

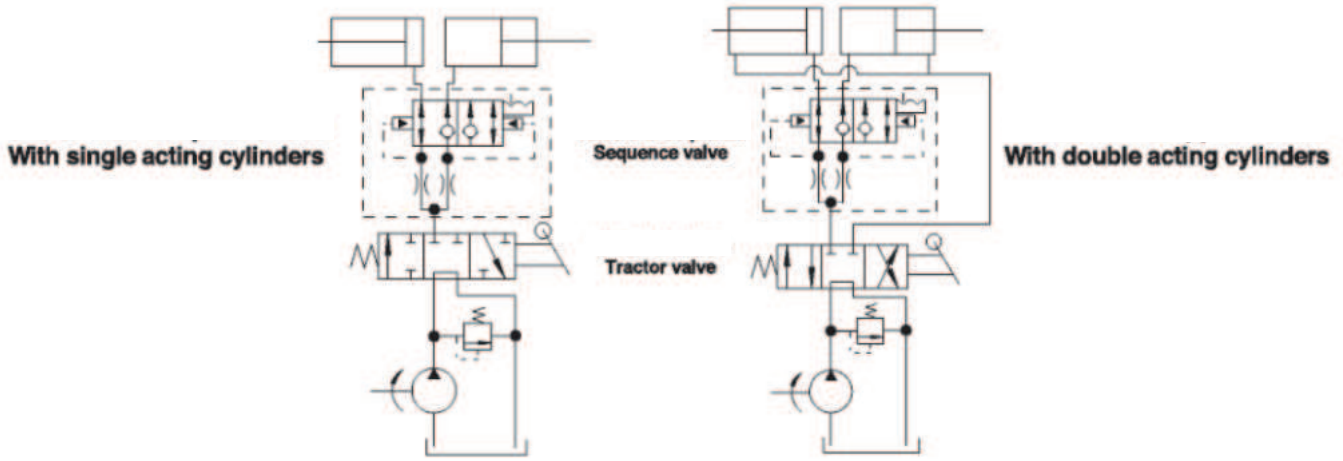
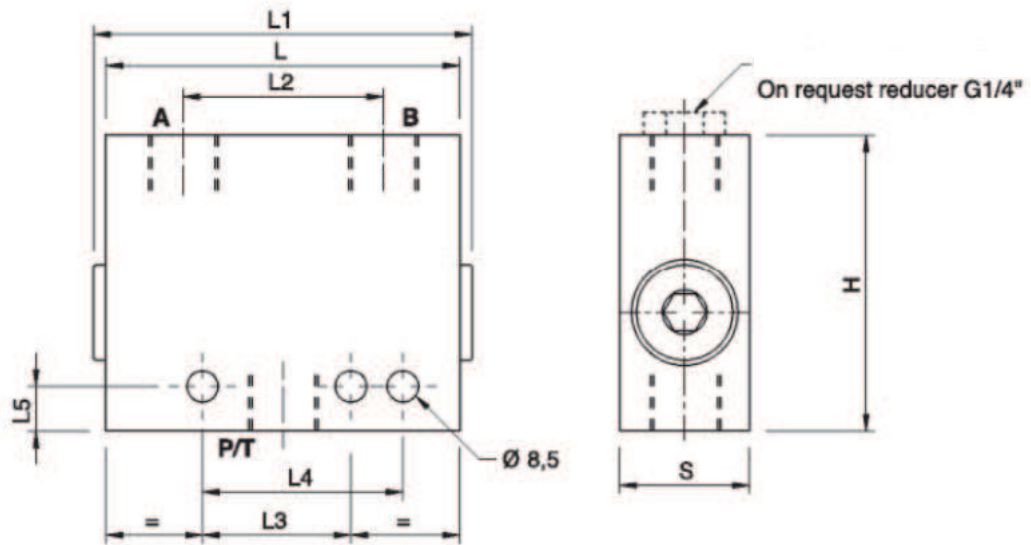

 **Ordering Details**

Code	Type	A-B	L	L1	L2	L3	L4	L5	H	S	Weight
		P/T									
R-VI450	VDFS 3/4" - 16 UNF	3/4" - 16	94	102	54	40	54	12	80	35	1.830

 **On Request**

The valve can be supplied with:

- 1/4" female adaptation
- Fitting for DIN 12L hose connection

**DUAL CROSS RELIEF VALVES**