

END STROKE VALVES, NORMALLY CLOSED



V-FCR 2T

Flow Upto 120 LPM
Pressure 350 Bar

Description & Operation

This valve is used to open the inlet to a hydraulic circuit (Valve normally closed). The valve opens by pulling or pushing the spool.

Connect P to the control valve and A to the circuit when spool is operated, flow is free in both directions. When spool is not operated the flow is blocked.

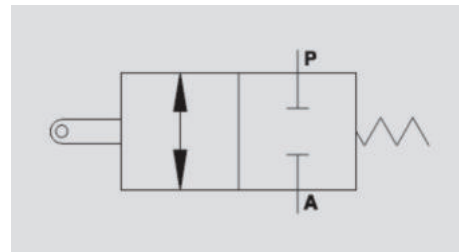

Hydraulic Symbol

Technical Data

Maximum Flow	120 LPM
Maximum Pressure	350 Bar
Body Material	Cast Iron
Internal parts	Hardened and Ground steel
Oil Temperature	50 Deg. C
Fluids	Mineral based or synthetics with lubricating properties
Viscosity	30 cSt
Standard Sealing	NBR-Buna N
Filtration	20/18/15 ISO 4406 (Max. Filtration admitted)
Orientation / Mounting	Inline
Weight	See Ordering details

Specifications

Type	Max Flow	Max.Pressure	Start Closing	Power	Max Stroke	Power
	LPM	Bar	mm	Kg (±10%)	mm	Kg (±10%)
V-FCR 2T 60	60	350	7	6.5	12	18
V-FCR 2T 80	80	350	7	6.5	12	18
V-FCR 2T 120	120	350	9	33	17	50

 **Performance Curve**

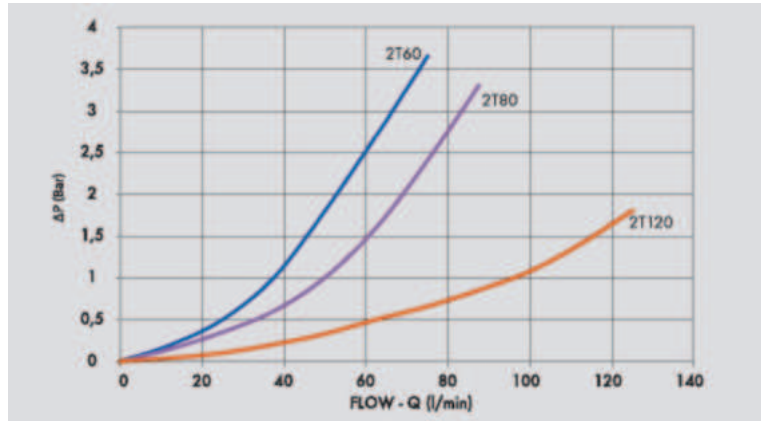

 **Dimensional Drawing**

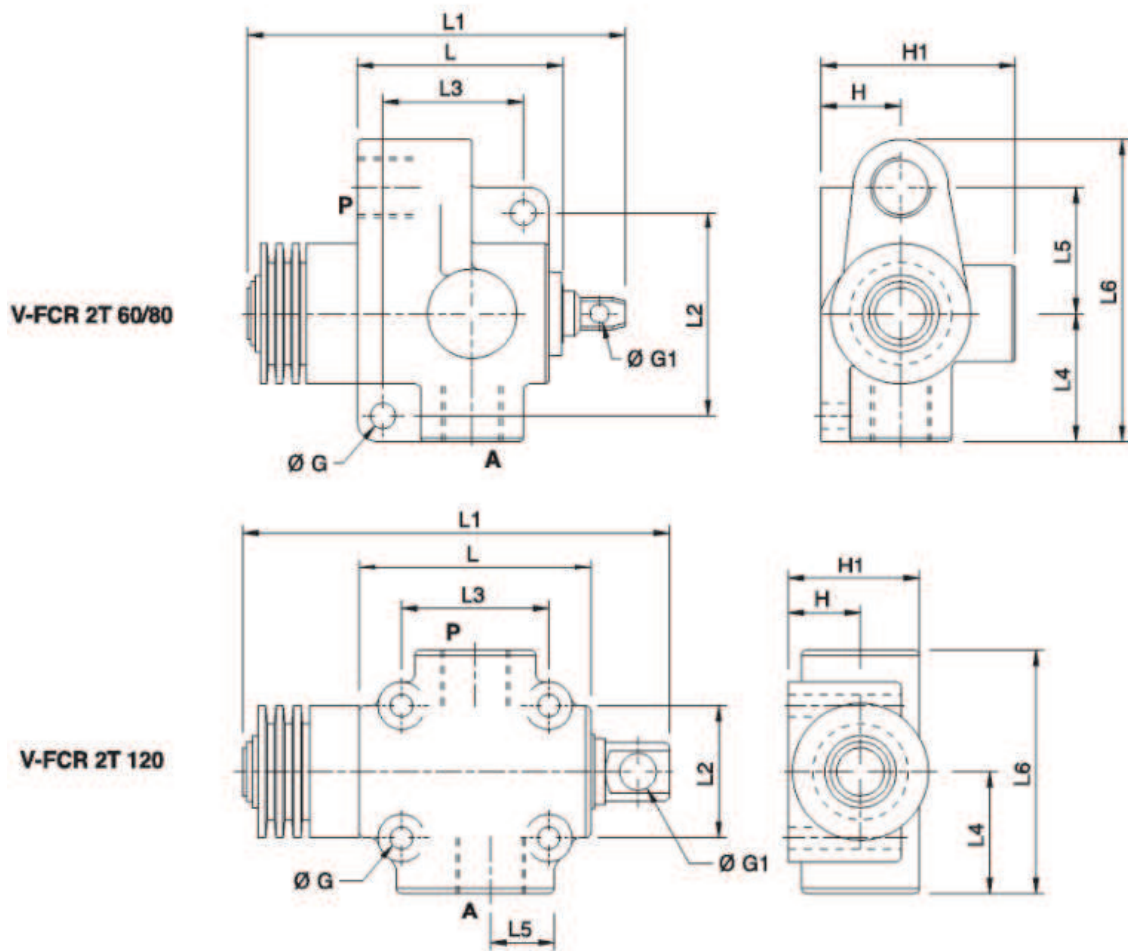

 **Ordering Details**

Code	Type	A-P	L	L1	L2	L3	L4	L5	L6	ØG	ØG1	H	H1	Weight
		GAS	mm	mm	mm	mm	mm	mm	mm	mm	mm	mm	mm	Kg
R-V0820	V-FCR 2T 60	G 3/8"	69	130	66	45	45	41	103	8.5	6.5	26	68	1.648
R-V0822	V-FCR 2T 80	G 1/2"	69	130	66	45	45	41	103	8.5	6.5	26	68	1.652
R-V0823	V-FCR 2T 120	G 3/4"	88	179	50	56	46	23.5	92	8.5	13	27.5	50	2.204

END OF STOKE VALVES