



# Check Valves

## IS.0.M27 Valve Series

**METRIC Insert - 420 Bar**

**Direct acting - Poppet type**



### Description & Operation

A screw-in, direct acting, poppet type check valve. Main use is as a blocking or load-holding device. The IS.0.M27 allows flow passage from port 1 to 2: the cartridge has a fully guided check which is spring-biased closed until sufficient pressure is applied at port 1 to open to 2. The flow is blocked in the opposite direction (2 to 1). Insert type valve: the poppet seals directly against the cavity.



Hydraulic Symbol



### Technical Data

Maximum operating pressure	420 Bar
Maximum flow	150 l/min
Maximum internal leakage	0.10 cm <sup>3</sup> / min @ 10 Bar 0.10 cm <sup>3</sup> / min @ 420 Bar
External component treatment	Zn/Fe - standard (96h) Zn/Ni (720h)
O-ring Temperature Range	-30° C to 110° C (standard sealing NBR - BUNA-N)
Oil Temperature Range	-30° C to 110° C
Fluids	Mineral - based or synthetics with lubricating properties
Viscosities	7.4 to 420 cSt
Filtration	20/18/15 ISO 4406 (maximum filtration admitted)
Orientation	No restrictions
Installation torque	70 - 80 Hex 24
Oil testing condition	ISO VG 46 cSt
Seal kit code	SLKT.044
Coining Kit	CK.005
Weight	0.113 kg

**Performance Curve**

Spring N

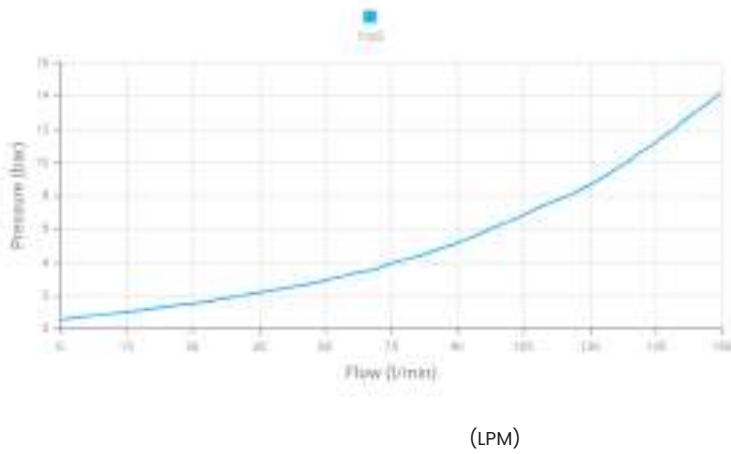

**Note:**

The performance chart illustrates flow handling capacity for standard bias springs. p/Q curves are recorded at TOil = 40°C and 46 cSt

**Dimensional Drawing**

**Cross Section and Cavity Details**

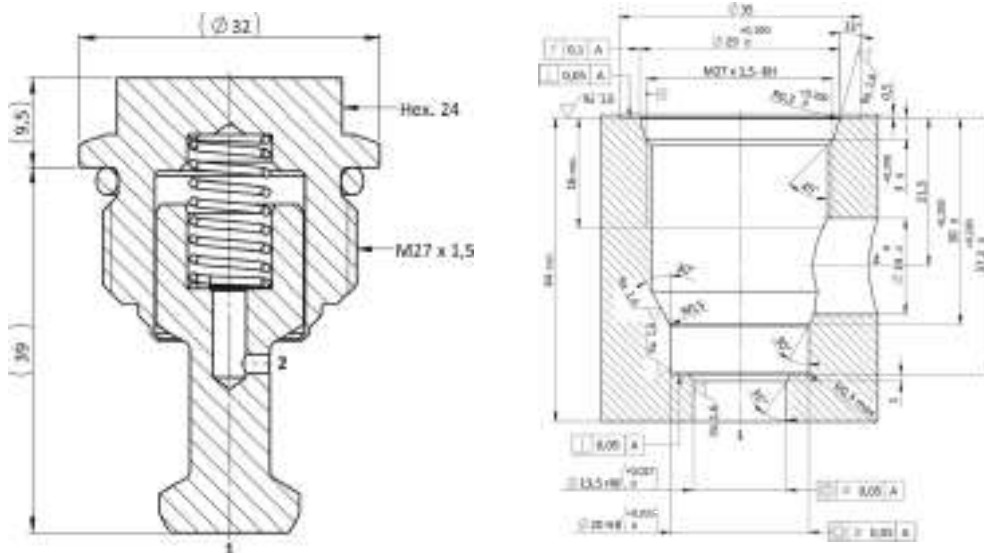

**Ordering Code**

I	S	•	0	•	M	2	7	•	0	*	•	0	0	0
valve basic code			Cavity M27 = METRIC M27 x 1.5							Marking 0 = standard factory marking, customized marking can be done upon request				
											Bias Spring Options			
											Spring Model Code		Cracking Pressure (Bar)	
											N		0,5	

000 = standard configuration