



IS.0.M24 Valve Series

METRIC Insert - 420 Bar

Direct acting - Poppet type



Description & Operation

A screw-in, direct acting, poppet type check valve. Main use is as a blocking or load-holding device. The IS.0.M24 allows flow passage from port 1 to 2: the cartridge has a fully guided check which is spring-biased closed until sufficient pressure is applied at port 1 to open to 2. The flow is blocked in the opposite direction (2 to 1). Insert type valve: the poppet seals directly against the cavity



Hydraulic Symbol



Technical Data

Maximum operating pressure	420 Bar
Maximum flow	100 LPM
Maximum internal leakage	0.10 cm ³ / min @ 10 Bar 0.10 cm ³ / min @ 420 Bar
External component treatment	Zn/Fe - standard (96h) Zn/Ni (720h) upon request
O-ring Temperature Range	-30° C to 110° C (standard sealing NBR - BUNA-N)
Oil Temperature Range	-30° C to 110° C
Fluids	Mineral - based or synthetics with lubricating properties
Viscosities	7.4 to 420 cSt
Filtration	20/18/15 ISO 4406 (maximum filtration admitted)
Orientation	No restrictions
Installation torque	50 - 55 Nm Hex 19
Oil testing condition	ISO VG 46 cSt
Seal kit code	SLKT.009
Coining Kit	CK.004
Weight	0.100 kg

CROSS SECTION

Performance Curve

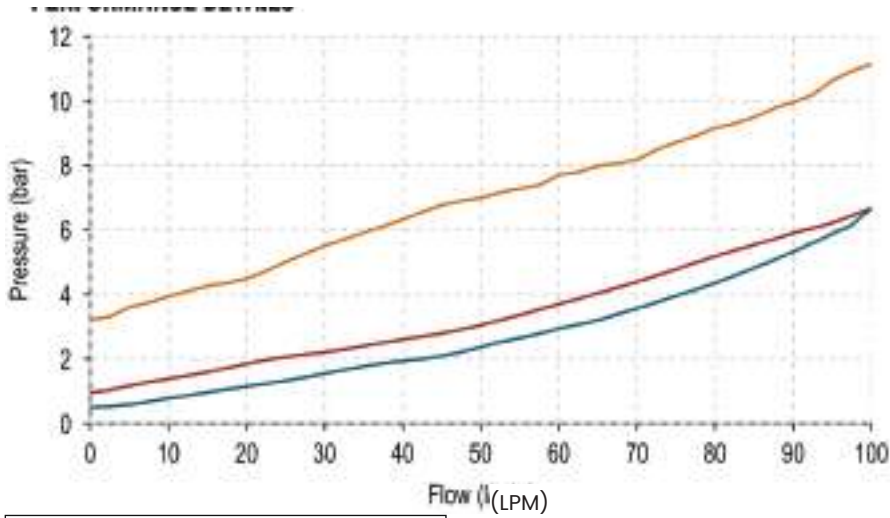

Note:
The performance chart illustrates flow handling capacity for standard bias springs. p/Q curves are recorded at TOil = 40°C and 46 cSt

Dimensional Drawing

Cross Section and Cavity Details

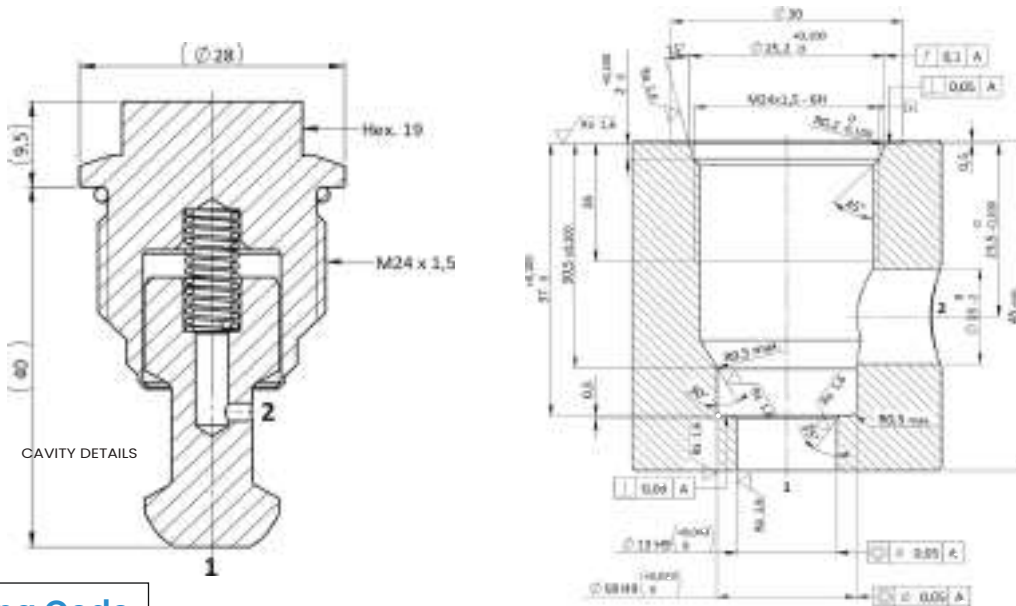

Ordering Code

I **S** **•** **0** **•** **M** **2** **4** **•** **0** ***** **•** **0** **0** **0**

valve basic code 000= standard configuration

Cavity
M24= METRIC M24 x 1.5

Marking
0 =standard factory marking. customized marking can be done upon request

Bias Spring Options

Spring Model Code	Cracking Pressure (Bar)
N	0,5
B	1,0
G	3,0