

DOUBLE PILOT OPERATED CHECK VALVES WITH MANUAL SHUT-OFF



VBPDE c/RUB.

Flow Upto 50 LPM
Pressure 350 Bar

Description & Operation

Pilot check valves with integrated manual shut-off used to block the actuator in both directions. Flow is free in one direction and blocked in the reverse direction until pilot pressure is applied. Due to the high safety of these valves they are particularly suitable for fitting onto the stabiliser cylinders: closing of the manual shut-off valve, after the lowering of the stabiliser legs, would prevent any potential accidental movements. Connect V1 and V2 to the pressure flow and C1 and C2 to the actuator.

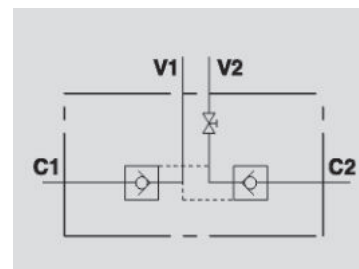

Hydraulic Symbol

Technical Data

Maximum Flow	50 LPM
Maximum Pressure	350 Bar
Body Material	Steel
Internal Material	Hardened and Ground steel
External Component treatment	Zn/Fe - standard (96h) / Zn/Ni (720h)
Oil Temperature	50 Deg. C
Fluids	Mineral based or synthetics with lubricating properties
Viscosity	30 cSt
Standard Sealing	NBR-Buna N
Filtration	20/18/15 ISO 4406 (Max. Filtration admitted)
Orientation / Mounting	Inline
Weight	See Ordering details

Specifications

Type	Pilot Ratio	Max.Flow	Max.Pressure	Cr.Pressure
		LPM	Bar	Bar
VBPDE 1/4" L c/RUB.	1:5.5	20	350	4
VBPDE 3/8" L c/RUB.	1:5.5	30	350	3
VBPDE 1/2" L c/RUB.	1:5	50	350	3
VBPDE 1/4" L c/RUB. 2 CEXC	1:5.5	20	350	4
VBPDE 3/8" L c/RUB. 2 CEXC	1:5.5	30	350	4
VBPDE 1/2" L c/RUB. 2 CC	1:5	50	350	3

Performance Curve

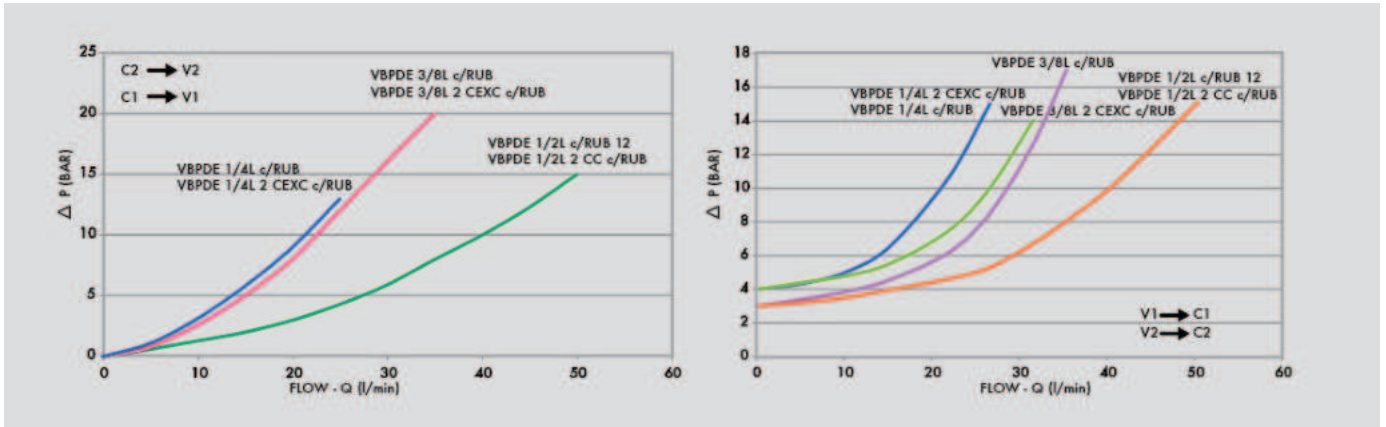

Dimensional Drawing

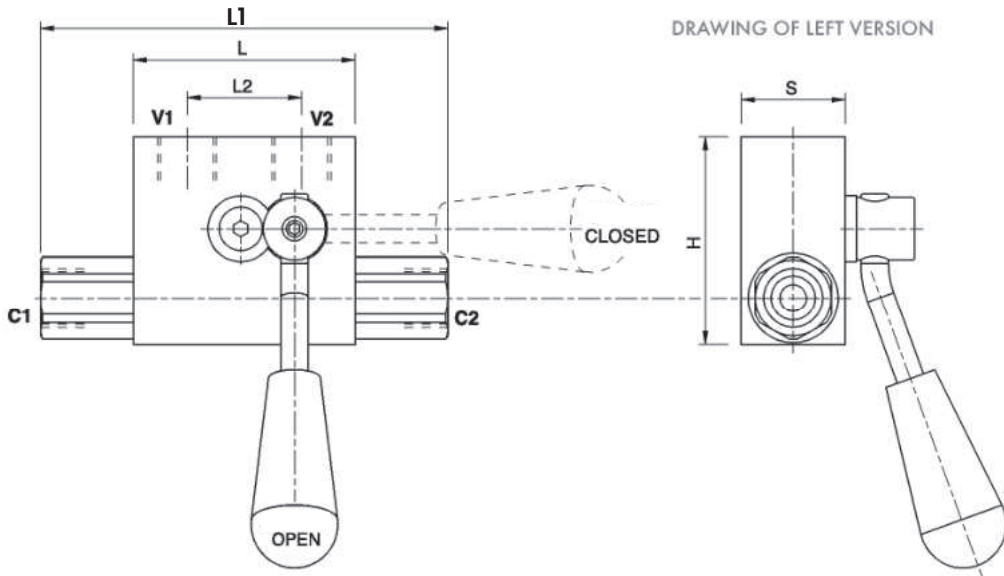

Ordering Details

Code	Type	V1-V2	C1-C2	L	L1	L2	H	S	Weight
		GAS	GAS	mm	mm	mm	mm	mm	Kg
R-V0072	VBPDE 1/4" L c/RUB.	G 1/4"	G 1/4"	64	113	34	60	30	0.994
R-V0074	VBPDE 3/8" L c/RUB.	G 3/8"	G 3/8"	64	118	34	60	30	0.964
R-V0076	VBPDE 1/2" L c/RUB.	G 1/2"	G 1/2"	90	142	45	75	35	1.708
R-V0132	VBPDE 1/4" L c/RUB. 2 CEXC	G 1/4"	12L	64	134	34	60	30	1.006
R-V0134	VBPDE 3/8" L c/RUB. 2 CEXC	G 3/8"	12L	64	134	36	60	30	0.982
R-V0136	VBPDE 1/2" L c/RUB. 2 CC	G 1/2"	15L	90	164	45	75	35	1.752

On Request

- Without seal on pilot piston
- Right or left side lever (to specify in the order)
- Ports C1-C2 12L and 15L (DIN 2353)