



DB.P0.M27 Valve Series

METRIC Cartridge - 420 bar
Pilot Operated with anti-cavitation
Poppet type

Description & Operation

The DB.P valve combines in one compact cartridge the typical function of relief valve and anticavitation through the check valve. It's a screw-in, pilot operated (2-stage), poppet type, normally closed valve. When the pressure at the Inlet (1) reaches the valve setting, the pilot poppet starts to open from its seat and determines the shifting of the main stage poppet that throttles oil flow to tank (2). In the free reverse flow function a light bias spring allows for ease of flow passage from side to nose (2 to 1). The cartridge offers smooth transition in response to load changes in demanding hydraulic circuits. Smooth response, reduced pressure rise and limited hysteresis.

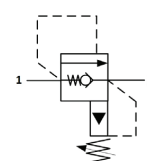
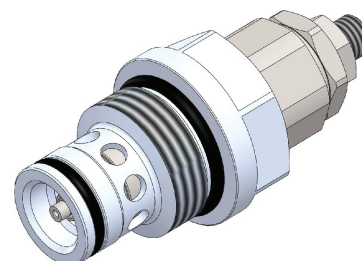

Hydraulic Symbol

Technical Data

Maximum operating pressure	420 bar
Maximum flow	100 LPM
Setting Pressure	50 - 420 bar
Anti-cav cracking pressure	<2 bar
Maximum internal leakage	1 cm ³ /min @ 100 bar
External component treatment	Zn/Fe - standard (96h) Zn/Ni (720h) upon customer request
O-ring Temperature Range	-30° C to 110° C (standard sealing NBR - BUNA-N)
Oil Temperature Range	-30° C to 110° C
Pressure settings established	@ 10 LPM
Reset pressure	90% of cracking pressure
Fluids	Mineral - based or synthetics with lubricating properties
Viscosities	7,4 to 420 cSt
Filtration	20/18/15 ISO 4406 (maximum filtration admitted)
Orientation	No restrictions
Installation torque	70-80 Nm Hex. 32
Tightening torque nut	15-20 Nm Hex. 13
Oil testing condition	ISO VG 46 cSt
Seal kit code	SLKT.056
Wire seals tamper proof	Suitable design upon request
Weight	0,205 kg

Performance Curve

Anti-cavitation function

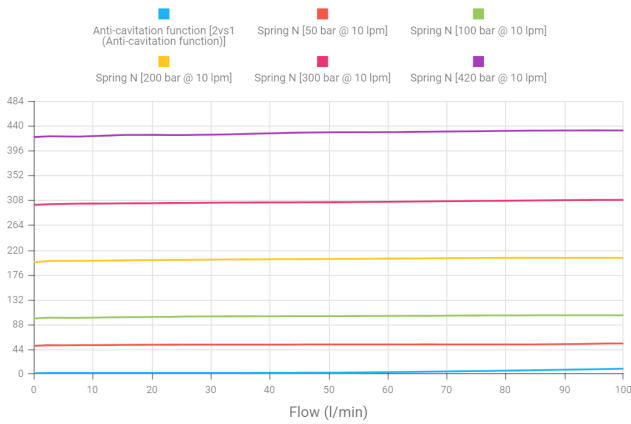

Note: : The performance chart illustrates flow handling capacity at various settings. p/Q curves are recorded at TOIL = 40°C and 46 cSt

Dimensional Drawing

Cross Section and Cavity Details

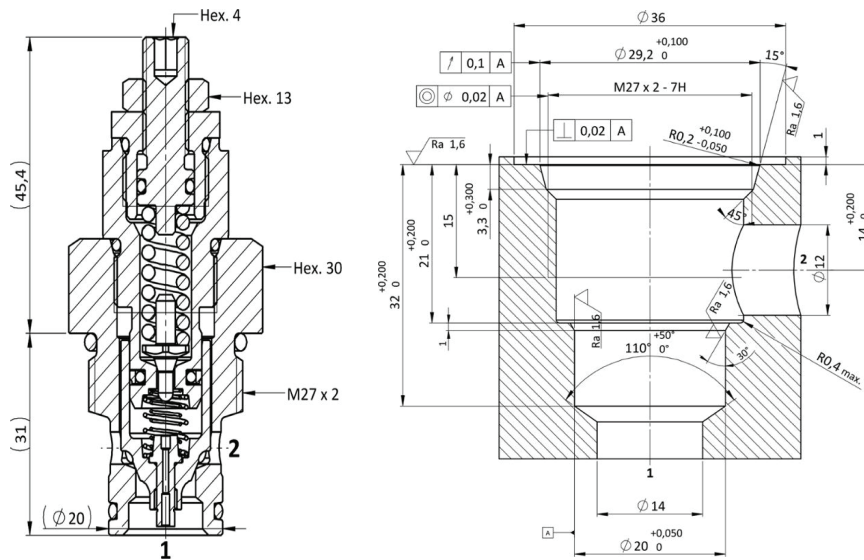

Ordering Code

D B • P 0 • M 2 7 • 0 * • 0 0 0

valve basic code

Cavity
M27 = METRIC M27 x 2 with ø20 nose size.

Marking
0 = standard factory marking. customized marking can be done upon request

Setting Pressure in (bar)
000= no specific setting required

Total spring range
(50 - 420 bar)

Spring Model Code	Setting Pressure Range (Bar)	Pressure Increment Per Turn[Bar/turn}
N	50 - 420	283