



DB.CO.S08 Valve Series

SAE08 Cartridge – 350 Bar
Direct acting – Poppet type

Description & Operation

A screw-in, cartridge style, direct acting, poppet type, normally closed hydraulic relief valve. It's typically used to protect hydraulic components from pressure transients. When the pressure at the Inlet (1) reaches the valve setting, the valve starts to open to tank (2) throttling flow to minimize the pressure rise. The innovative geometry of the deflector provides in fact a very low rise rate, and the poppet design guarantees great stability. The cartridge offers quick response to load changes in hydraulic circuits requiring low internal leakage as well as limited hysteresis. NOTE : the DB.CO in the standard configuration can be used in crossover relief applications.

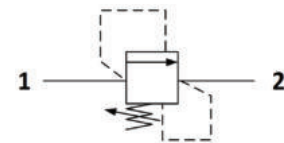
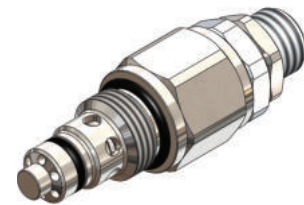

Hydraulic Symbol

Technical Data

Maximum operating pressure	350 Bar
Maximum flow	30 LPM
Setting Pressure	See table below
Maximum internal leakage	0.25 cm ³ /min to 80% of nominal set point
External component treatment	Zn/Fe - standard (96h) Zn/Ni (720h)
O-ring Temperature	-30° C to 110° C (standard sealing NBR - BUNA-N)
Oil Temperature Range	-30° C to 110° C
Pressure settings established	@5 l/min
Reseat pressure	nominal 90% of cracking pressure
Fluids	Mineral - based or synthetics with lubricating properties
Viscosities	7.4 to 420 cSt
Filtration	20/18/15 ISO 4406 (maximum filtration admitted)
Orientation	No restrictions
Installation torque	40-45 Nm (Hex. 24)
Tightening torque nut	25-30 Nm (Hex. 19)
Oil testing condition	ISO VG 46 cSt
Seal kit code	SLKT.003
Plastic tamper proof cap	CTP.001
Weight	0.145 kg

 Performance Curve

Cross Section and Cavity Details

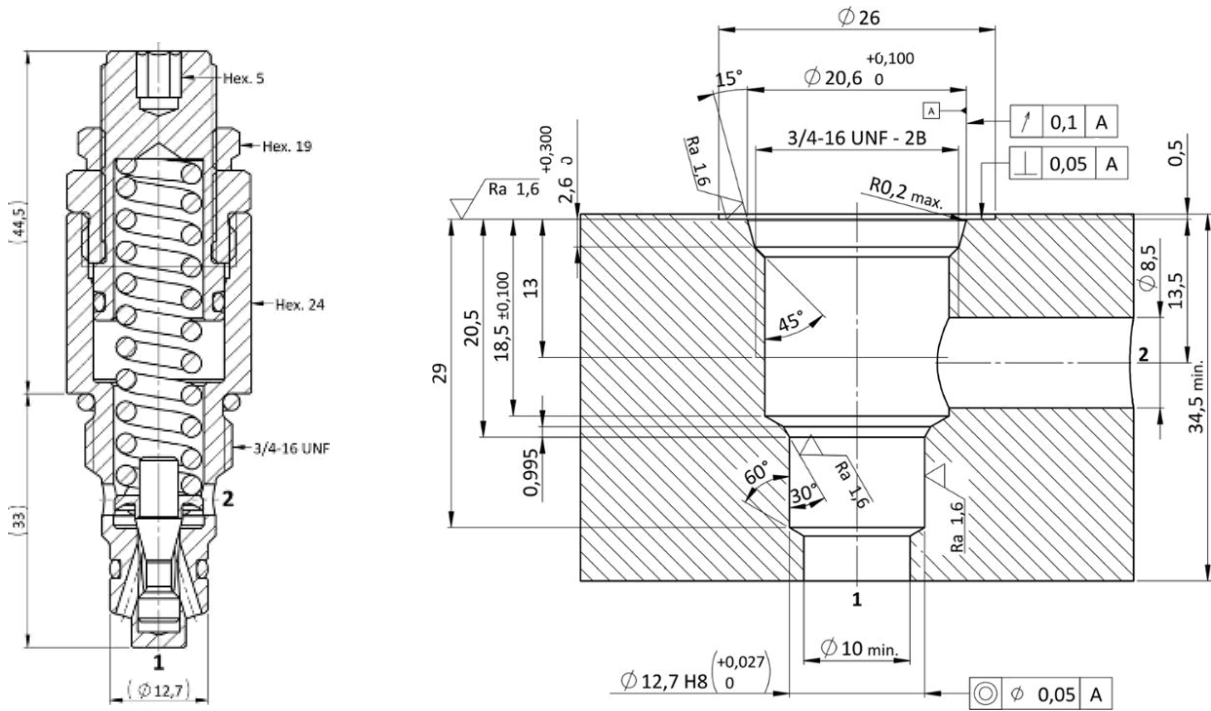

RELIEF VALVES

 Ordering Code

D B • A 0 • M 1 6 • 0 * • * * *

valve basic code

Cavity
S08 = 3/4-16 UNF with
ø12.7 nose sizes

Marking
0 = standard factory
marking. customized
marking can be done
upon request

pressure setting in (bar)
000=No specific setting
required

Spring range

Spring model Code	Pressure setting range (Bar)	Pressure Increment per turn (Bar)
Y	15-60	8
N	25-135	20
B	50-220	34
G	120-350	59

 Spring Graph

- Spring = Y

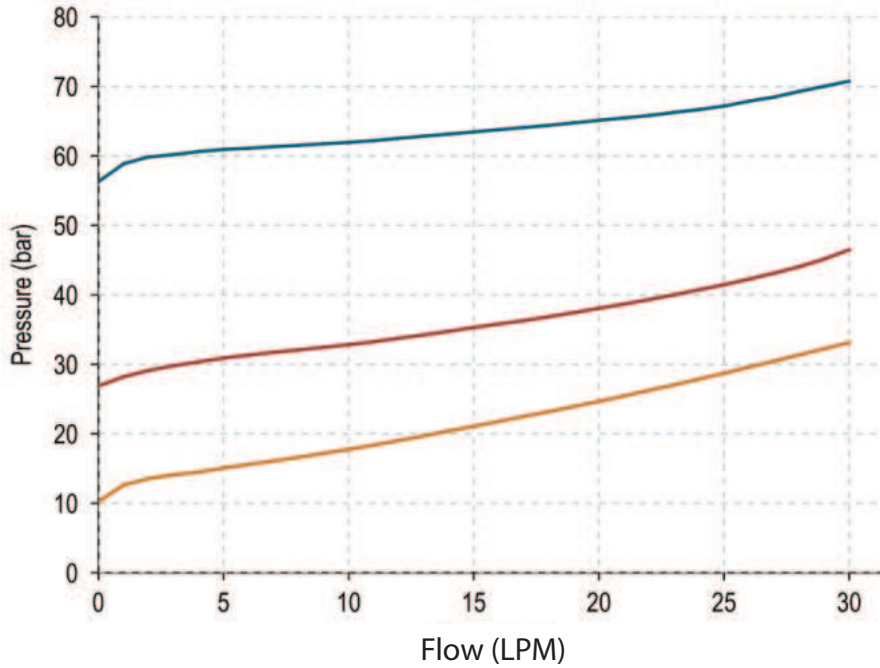

- Spring = N

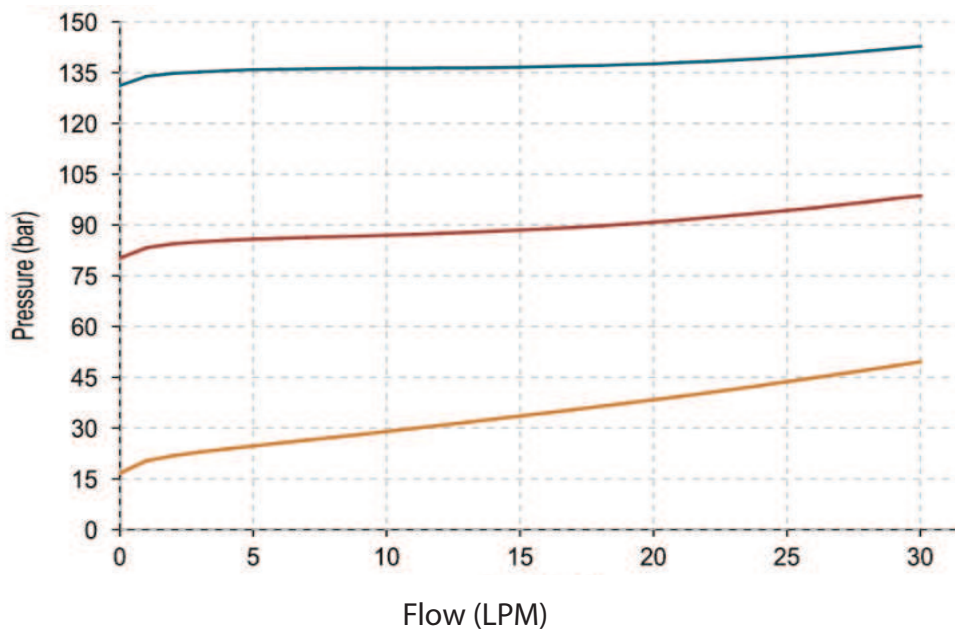

 Spring Graph

● Spring = B

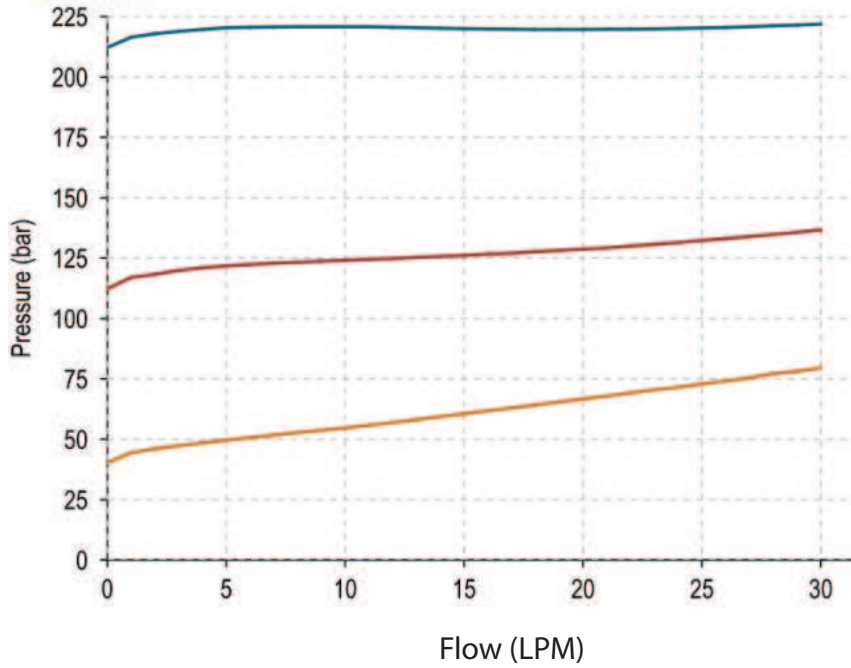

● Spring = G

