



## SP.C6.S10 Valve Series

**SAE Cartridge – 350 Bar**  
**Direct acting check valve**  
**Pilot piston to open**

### Description & Operation

Cartridge style, normally closed, single pilot check valve. Cartridge is closed until sufficient pressure is applied on port 1 to reach the bias spring setting, lift the poppet and allow free flow to 2. The valve is normally closed from 2 to 1. When sufficient pressure is applied on port 3, the pilot piston lifts the poppet from its seat and allows flow from 2 to 1. Very limited leakage in the check condition.

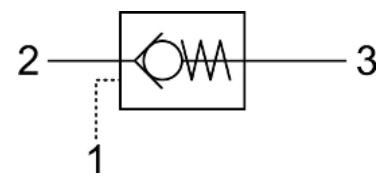

Hydraulic Symbol

### Technical Data

Maximum operating pressure	350 Bar
Maximum flow	60 LPM
Maximum internal leakage	0.10 cm <sup>3</sup> / min @ 10 Bar 0.10 cm <sup>3</sup> / min @ 350 Bar
Pilot Ratio	3:1
External component treatment	Zn/Fe - standard (96h) Zn/Ni (720h)
O-ring Temperature Range	-30° C to 110° C (standard sealing NBR - BUNA-N)
Oil Temperature Range	-30° C to 110° C
Fluids	Mineral - based or synthetics with lubricating properties
Viscosities	7.4 to 420 cSt
Filtration	20/18/15 ISO 4406 (maximum filtration admitted)
Orientation	No restrictions
Installation torque	55-65 Nm
Oil testing condition	ISO VG 46 cSt
Seal kit code	SLKT.049
Weight	0.103 kg

**Performance Curve**

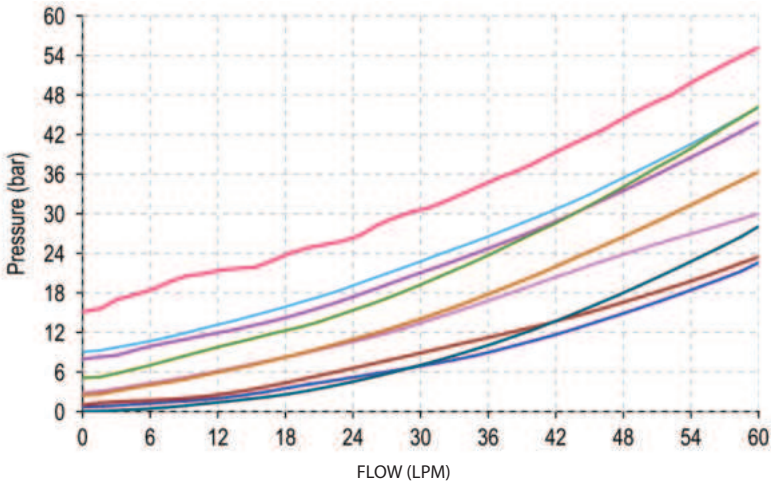

**Note:**  
The performance chart illustrates flow handling capacity for standard bias springs. p/Q curves are recorded at TOil = 40°C and 46 cSt

**Dimensional Drawing**

**Cross Section and Cavity Details**

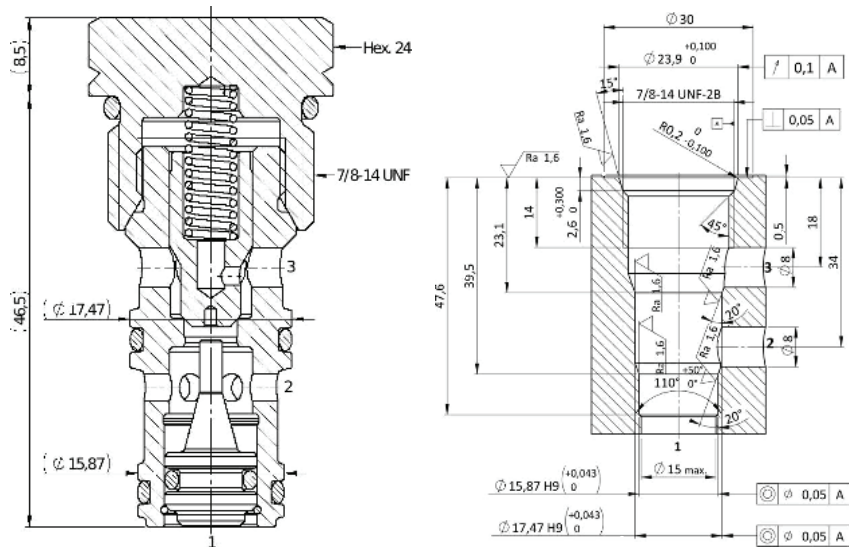

**Ordering Code**

**S P • C 6 • S 1 0 • 0 \* • 0 0 0**

valve basic code

**Options**  
7=Without O-Ring on the pilot piston

**Cavity**  
S10 = 7/8 - 14 UNF with ø17.47 and ø15.87 nose size

**Marking**  
0 = standard factory marking, customized marking can be done upon request

000= standard configuration

**Bias spring**

Spring model Code	Cracking Pressure (Bar)	Spring model Code	Cracking Pressure (Bar)
Y	< 0.5	P	5.0
N	1.0	G	8.0
S	2.5	V	9.0
B	3.0	W	15.0

PILOT CHECK VALVES