



S.D0.S08 Valve Series

SAE Insert – 350 Bar

Direct acting – Poppet type



Description & Operation

A screw-in, direct acting, poppet type in-line check valve. Main use is as a blocking or load-holding device. The S.D0.S08 allows flow passage from port 1 to 2: the cartridge has a fully guided check which is spring-biased closed until sufficient pressure is applied at port 1 to open to 2. The flow is blocked in the opposite direction (2 to 1).

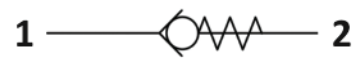

Hydraulic Symbol



Technical Data

Maximum operating pressure	350 Bar
Maximum flow	80 LPM
Maximum internal leakage	0.1 cm ³ / min @ 10 Bar 0.1 cm ³ / min @ 350 bar
External component treatment	Zn/Fe - standard (96h) Zn/Ni (720h)
O-ring Temperature Range	-30° C to 110° C (standard sealing NBR - BUNA-N)
Oil Temperature Range	-30° C to 110° C
Fluids	Mineral - based or synthetics with lubricating properties
Viscosities	7.4 to 420 cSt
Filtration	20/18/15 ISO 4406 (maximum filtration admitted)
Orientation	No restrictions
Installation torque	10 Nm
Oil testing condition	ISO VG 46 cSt
Seal kit code	SLKT
Weight	0.016 kg

Performance Curve

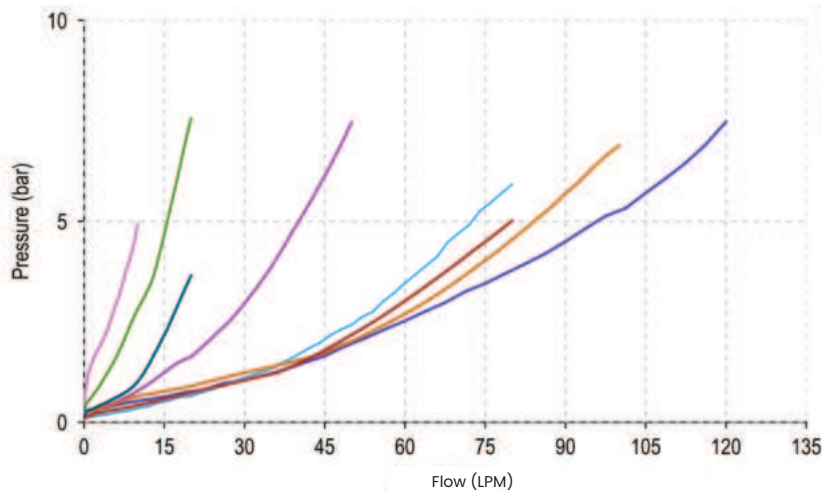

Note:
The performance chart illustrates flow handling capacity. p/Q curves are recorded at TOil = 40°C and 46 cSt.

Dimensional Drawing

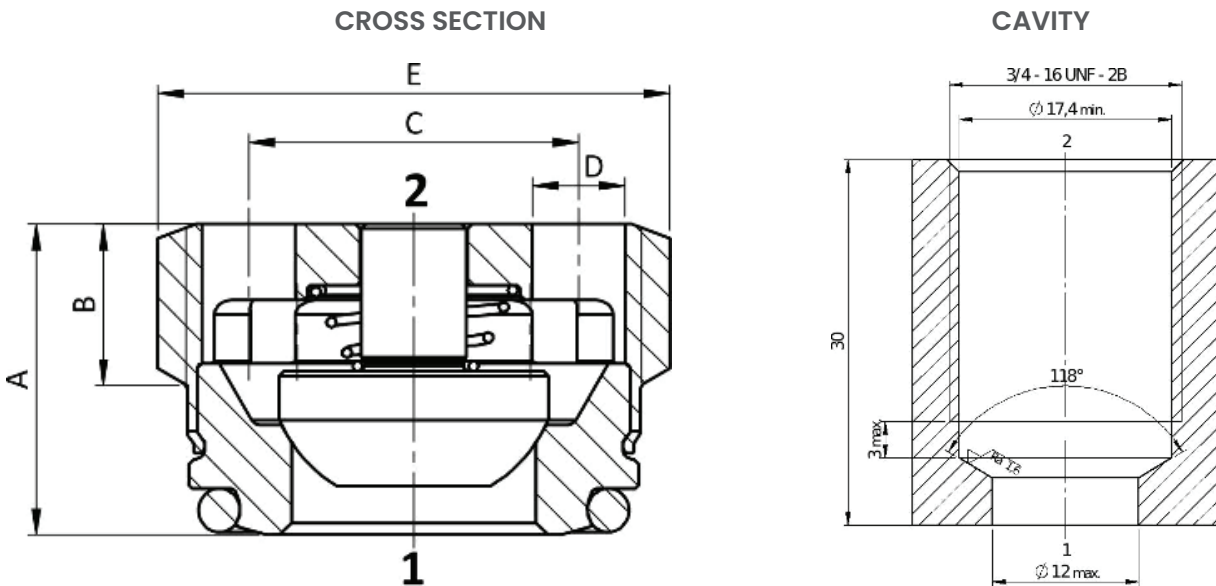

Ordering Code

C V D 0 • *** * *** • **0 *** • **0 0 0**

Valve Basic Code • Marking • Bias Spring Options

000= standard configuration

Cavity
S08 = METRIC S08 x 1

Marking
0 = standard factory marking. customized marking can be done upon request

Bias Spring Options

Spring Model Code	Cracking pressure (Bar)
X	3.0
Y	118
Z	12,9
W	07

CHECK VALVES