



Shuttle Valves

SH.CO.S08 Valve Series

SAE Cartridge - 210 Bar
Direct acting - Ball Type

Description & Operation

Shut-off valves for hydraulics systems, with two inlets and one outlet. Ball seat construction, automatic switching. The inlet with the higher pressure (port 1 or 3) is directly connected to tank (port 2), while the second inlet (port 3 or 1) is shut off.

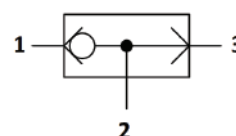

Hydraulic Symbol

Technical Data

Maximum operating pressure	210 Bar
Maximum flow	20 LPM
Maximum internal leakage	0.25 cm ³ / min @210Bar
External component treatment	Zn/Fe - standard (96h) Zn/Ni (720h)
O-ring Temperature Range	-30° C to 110° C (standard sealing NBR - BUNA-N)
Oil Temperature Range	-30° C to 110° C
Fluids	Mineral - based or synthetics with lubricating properties
Viscosities	7.4 to 420 cSt
Filtration	20/18/15 ISO 4406 (maximum filtration admitted)
Orientation	No restrictions
Installation torque	35-40 Nm (Hex. 22)
Oil testing condition	ISO VG 46 cSt
Seal kit code	SLKT.047
Weight	0.065 kg

Performance Curve

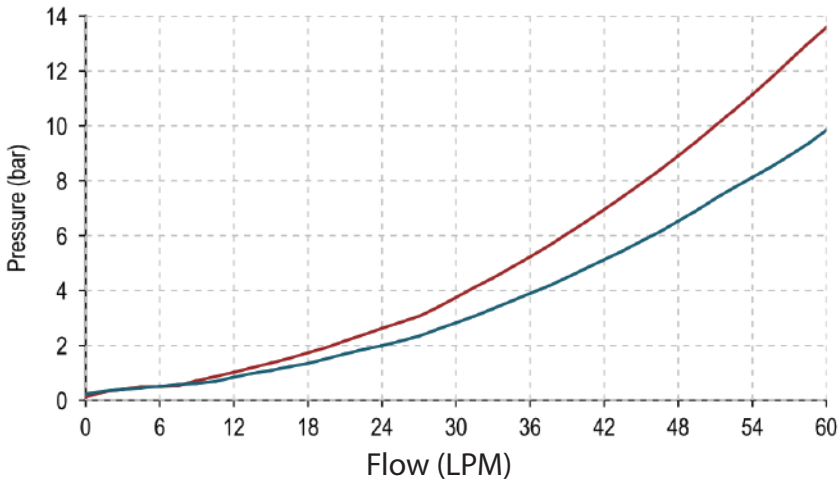

NOTE:

The performance chart illustrates flow handling capacity in max flow condition. p/Q curves are recorded at TOil = 40°C and 46 cSt.

Dimensional Drawing

Cross Section and Cavity Details

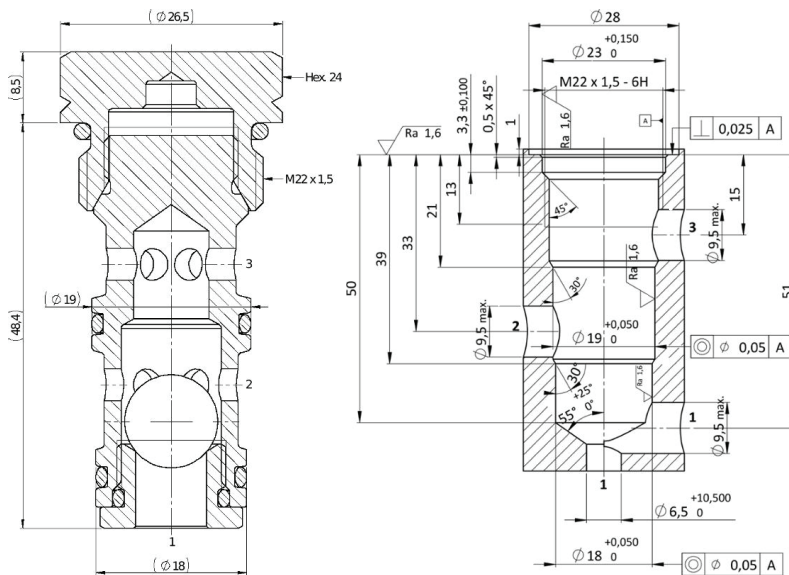

Ordering Code

S H • C O • S O 8 • 0 * • * * *

valve basic code

000=Standard configuration

Cavity
S08 = 3/4 - 16 UNF with
 15.87 and 14.27
 nose sizes

Marking
0 = standard factory
 marking. customized
 marking can be done
 upon request