

END STROKE VALVES, NORMALLY OPEN



V-FCR 1T

Flow Upto 120 LPM
Pressure 350 Bar



Description & Operation

This valve is used to block the oil supply to a hydraulic circuit or to stop an actuator's stroke (Valve is normally open) The valve is closed by either pulling or pushing the spool, which immediately stops the oil flow.

Connect P to the control valve and A to the actuator, When spool is operated, flow is blocked from P to A, whilst the check valve enables free flow in the reverse direction (from A to P).

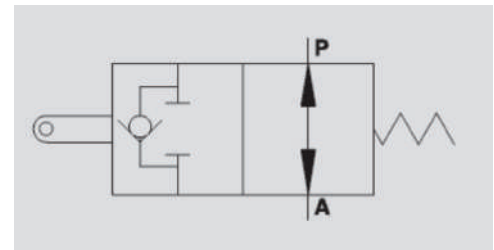

Hydraulic Symbol



Technical Data

Maximum Flow	120 LPM
Maximum Pressure	350 Bar
Body Material	Cast Iron
Internal parts	Hardened and Ground steel
Oil Temperature	50 Deg. C
Fluids	Mineral based or synthetics with lubricating properties
Viscosity	30 cSt
Standard Sealing	NBR-Buna N
Filtration	20/18/15 ISO 4406 (Max. Filtration admitted)
Orientation / Mounting	Inline
Weight	See Ordering details



Specifications

Type	Max Flow	Max. Pressure	Start Closing	Power	Max Stroke	Power
	LPM	Bar	mm	Kg (±10%)	mm	Kg (±10%)
V-FCR 1T 60	60	350	7	6.5	20.5	18
V-FCR 1T 80	80	350	7	6.5	20.5	18
V-FCR 1T 120	120	350	9	33	15.5	50

Performance Curve

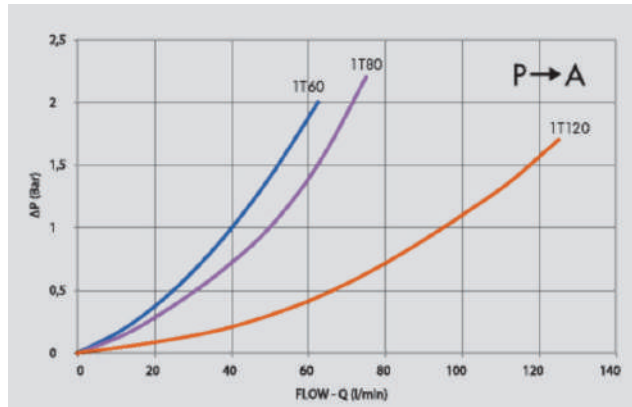

Dimensional Drawing

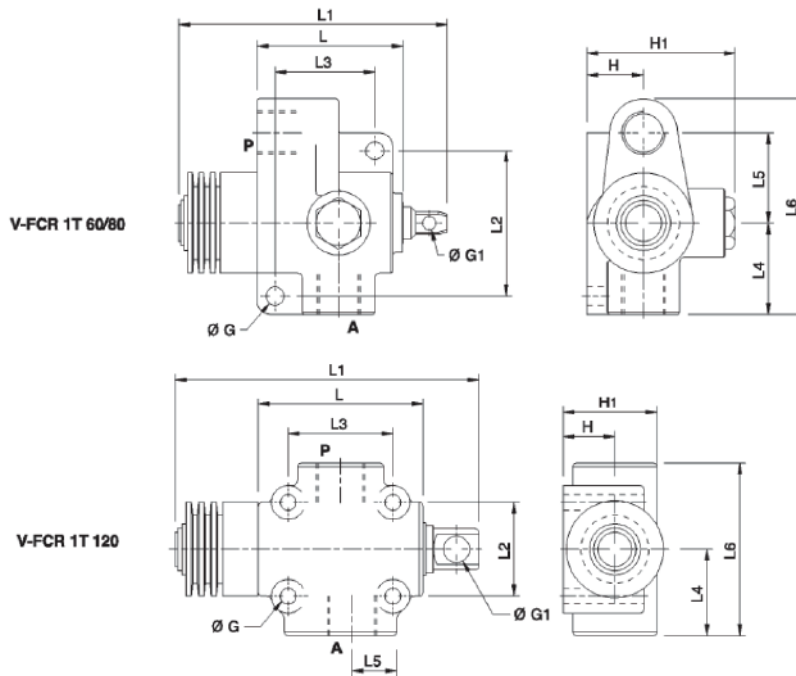

Ordering Details

Code	Type	A-P	L	L1	L2	L3	L4	L5	L6	ØG	ØG1	H	H1	Weight
		GAS	mm	mm	mm	mm	mm	mm	mm	mm	mm	mm	mm	Kg
R-V0824	V-FCR 1T 60	G 3/8"	69	130	66	45	45	41	103	8.5	6.5	26	68	1.628
R-V0826	V-FCR 1T 80	G 1/2"	69	130	66	45	45	41	103	8.5	6.5	26	68	1.616
R-V0825	V-FCR 1T 120	G 3/4"	88	173	50	56	46	23.5	92	8.5	13	27.5	50	2.112

END OF STOKE VALVES