

SINGLE PILOT OPERATED CHECK VALVE WITH MANUAL SHUT-OFF



VBPSE c/RUB.

Flow Upto 50 LPM
Pressure 350 Bar



Description & Operation

These valves, with integrated manual shut-off, are used to block the cylinder in one direction. Flow is free in one direction and blocked in the reverse direction until pilot pressure is applied. Due to the high safety of these valves they are particularly suitable for fitting onto the stabiliser cylinders: closing of the manual shut-off valve, after the lowering of the stabiliser legs, would prevent any potential accidental movements. Connect V1 and V2 to the pressure flow, C1 to the free flow side of the actuator and C2 to the actuator's side you want the flow to be blocked.

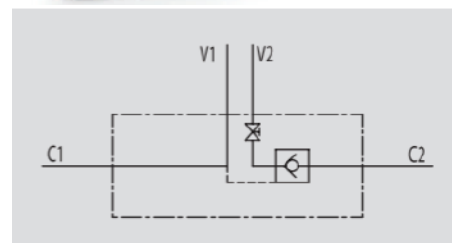

Hydraulic Symbol

Technical Data

Maximum Flow	50 LPM
Maximum Pressure	350 Bar
Body Material	Steel
Internal parts	Hardened and Ground steel
External Component treatment	Zn/Fe - standard (96h) / Zn/Ni (720h)
Oil Temperature	50 Deg. C
Fluids	Mineral based or synthetics with lubricating properties
Viscosity	30 cSt
Standard Sealing	NBR-Buna N
Filtration	20/18/15 ISO 4406 (Max. Filtration admitted)
Orientation / Mounting	Inline
Weight	See Ordering details

Specifications

Type	Pilot Ratio	Max.Flow	Max.Pressure	Cr.Pressure
		LPM	Bar	Bar
VBPSE 1/4" L c/RUB.	1:5.5	20	350	4
VBPSE 3/8" L c/RUB.	1:5.5	30	350	3
VBPSE 1/2" L c/RUB.	1:5	50	350	3
VBPSE 1/4" L c/RUB. 2 CEXC	1:5.5	20	350	4
VBPSE 3/8" L c/RUB. 2 CEXC	1:5.5	30	350	4
VBPSE 1/2" L c/RUB. 2 CC	1:5	50	350	3

Performance Curve

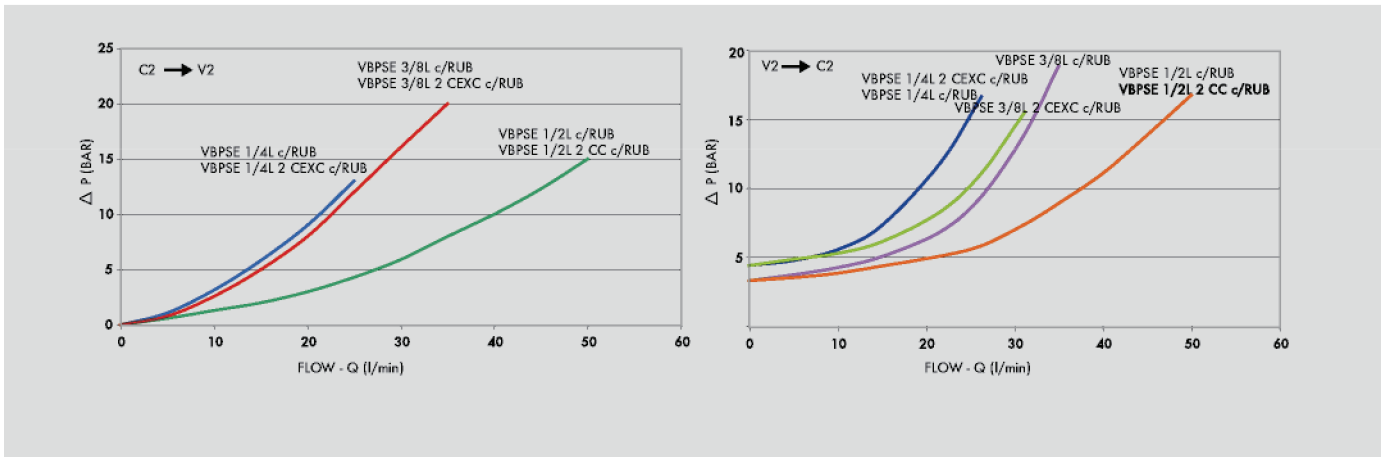

Dimensional Drawing

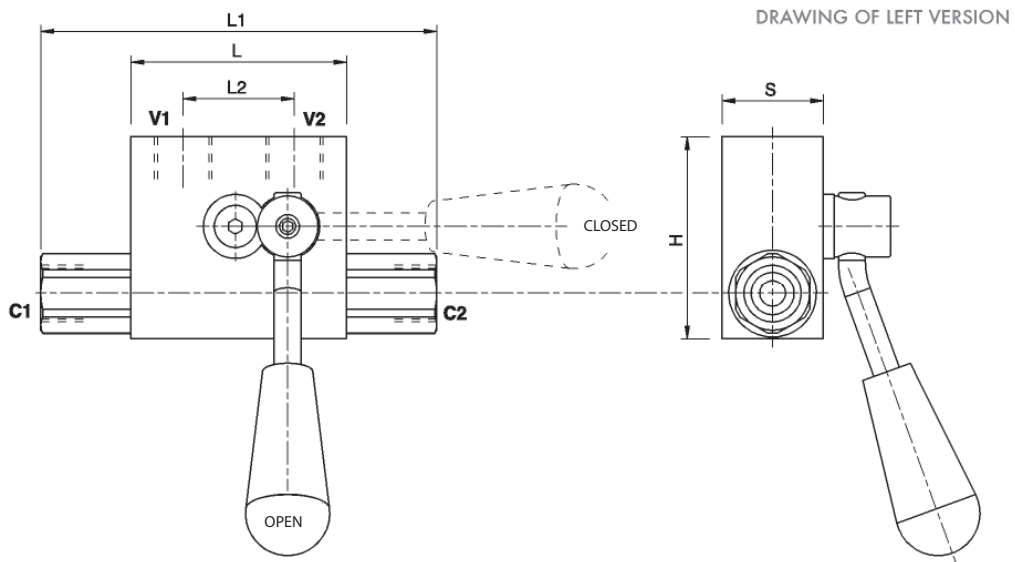

Ordering Details

Code	Type	V1-V2	C1-C2	L	L1	L2	H	S	Weight
		GAS	GAS	mm	mm	mm	mm	mm	Kg
R-V0072/SE/SX	VBPSE 1/4" L c/RUB.	G 1/4"	G 1/4"	64	113	34	60	30	0.994
R-V0074/SE/SX	VBPSE 3/8" L c/RUB.	G 3/8"	G 3/8"	64	118	34	60	30	0.964
R-V0076/SE/SX	VBPSE 1/2" L c/RUB.	G 1/2"	G 1/2"	90	142	45	75	35	1.708
R-V0132*/SE/SX	VBPSE 1/4" L c/RUB. 2 CEXC	G 1/4"	12L	64	131	34	60	30	1.006
R-V0134*/SE/SX	VBPSE 3/8" L c/RUB. 2 CEXC	G 3/8"	12L	64	131	36	60	30	0.982
R-V0136*/SE/SX	VBPSE 1/2" L c/RUB. 2 CC	G 1/2"	15L	90	164	45	75	35	1.752

*Fittings to DIN 2353

On Request

- Without seal on pilot piston
- Right or left side lever (to specify in the order)
- Ports C1 - C2 12L and 15L (DIN 2353)

SINGLE PILOT CHECK VALVES